

Wireless Technologies

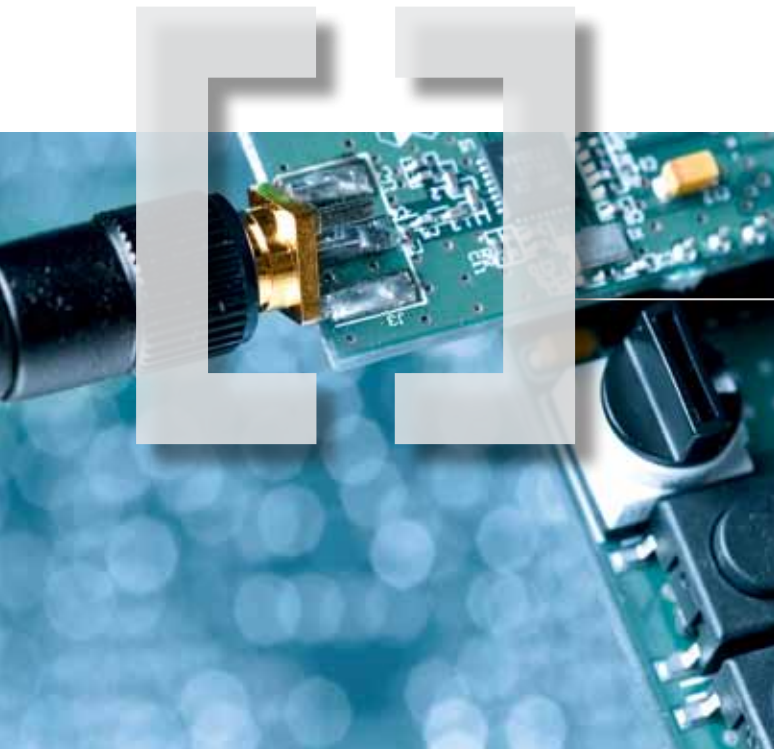

Committed to excellence

Cellular, GPS, RFID
and short range
wireless solutions



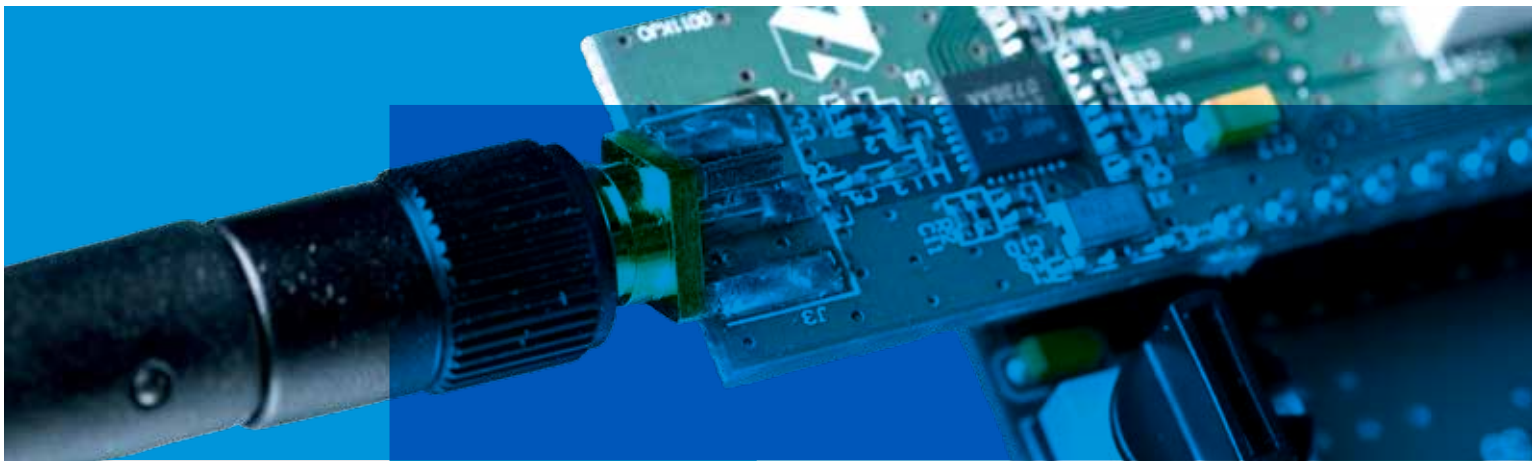

RFID	04 – 13
ISM/SRD	14 – 31
ZigBee	32 – 36
Bluetooth	33 – 43
Wireless LAN	44 – 47
GSM/GPRS/UMTS	48 – 58
Telemetry, Track & Trace	59 – 61
GPS	62 – 66
Medical / Industrial platform	67
Accessories	68 – 67

Committed to excellence

Consulting – Know-how. Built-in.

[The technical competence from Rutronik](#)

Pan-European and individual consulting on the spot: by competent sales staff, application engineers and product specialists.

Components – Variety. Built-in.

[The product portfolio from Rutronik](#)

Wide product range of semiconductors, passive and electro-mechanical components, displays & embedded boards, storage technologies, wireless technologies, lighting solutions and photovoltaic solutions for optimum coverage of your needs.

Logistics – Reliability. Built-in.

[The delivery service from Rutronik](#)

Innovative and flexible solutions: in supply chain management through individual logistics systems.

Support – Support. Built-in.

[The qualification drive from Rutronik](#)

Technical support: through online services, seminars, PCNs, quality management and much more.



Lars Mistander
Manager Wireless Competence Centre

Wireless Technologies portfolio

Rutronik has established its Wireless Competence Centre, based in Sweden and Germany, to consolidate pan-European support for wireless customers to include commercial and technical support, application development and development tools. We offer a wide range of short and long distance

wireless solutions from the world's leading suppliers. Together with the wireless core products, Rutronik also offers a comprehensive range of accessories such as antennas, SIM card holders, system connectors and adaptor cables.

	ANT	Fastrax	FREE2MOVE	Infineon	ITRONIC	MICROCHIP	mpuRutronik	FUJITSU	NORDIC	RENESAS	RFIDTAL	schreiner Group	silex technology	ST	Telic	Telit	ZMDI	Others
RFID																		
Active																		
Passive																		
ISM/SRD radio Prooritary																		
Transceivers																		
Transmitters																		
Receivers																		
Software Stack																		
IEEE 802.15.4 ZigBee																		
Chip Sets																		
Modules																		
Software Stack																		
Bluetooth*																		
Modules with Software Stack/Profiles																		
Modules with HCI Software Stack																		
Chip sets																		
WLAN																		
Modules 802.11 a/b/g/n																		
Software Stack																		
GSM/GPRS/UMTS																		
Modules																		
Terminals																		
With integrated GPS																		
Telematic & Telemetry Devices																		
GPS																		
Modules																		
Patch Modules (with Antenna)																		
Accessoires																		
Adapter Cables																		
Antennas																		
Connectors																		
SIM-card Holders																		

Please note that there are limitations for franchised product lines in some European countries. For more information, please contact our sales team.



FREE2MOVE

schreiner Group

RF DIGITAL
WWW.RFDIGITAL.COM

RFID

What does RFID mean?

RFID is a special kind of wireless communication to identify or count an object contactless. On one side you have a RFID-reader, like a terminal or handheld device. On the other side you have a transponder, like a tag or a label.

In a passive RFID system, the reader sends out a field of energy and data. The transponder uses the energy and data to read out his memory and sends the content back to the reader. At an Active-RFID system the transponder has its own battery, which allows much bigger memory sizes, a wider range and a faster communication.

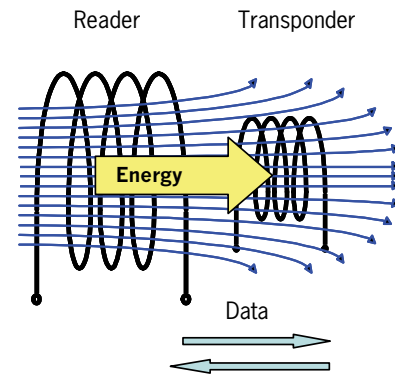

Parameter	Low frequency	High frequency	Ultra High frequency	Microwave
Frequency	125 kHz	13.56 MHz	868 MHz	2.4 GHz
Reading distance (max.)	1 m	1.5 m	10 m	80 m (active)
Reading rate	slow	Depending on ISO-Standards	fast	very fast (active transponder)
Humidity	No influence	No influence	Negative influence	Negative influence
Metal	Negative influence	Negative influence	No influence	No influence
ISO standards	11784/85, 14223 and 18000-2	14443, 15693 and 18000-3	14443, 15693 and 18000-6	18000-4
Applications	Admission control, going away barrier, scrubber agreement, gas reading	scrubber agreement, asset management, ticketing, tracking & tracing, group collection	Pallet collection, container-tracking	containertracking



iDTRONIC offers products for building passive and active RFID systems. They have a wide product portfolio from OEM readers and antenna multiplexer to a lot of different transponders. The readers and transponders have chips included from world's leading suppliers.



Passive RFID systems

OEM Read/Write Module 125 kHz

- Read/Write Module without antenna
- Interface options: TTL, RS232 or RS485
- Power supply options: 5V or 12V
- Different antenna options
- With external antenna possible to achieve up to 30 cm reading distance
- Supports EM4100, EM4550 and NXP Hitag1, NXP Hitag2, NXP HitagS



OEM Reader/Writer 125 kHz

- OEM Read/Write unit with integrated antenna
- Interface options: RS232 or USB
- Reading distance up to 8 cm
- Supports EM4100, EM4550 and NXP Hitag1, NXP Hitag2, NXP HitagS



OEM Read/Write Stick 125 kHz

- OEM Read/Write Stick with integrated antenna
- USB interface
- Reading distance up to 5 cm
- Supports EM4100, EM4550 and NXP Hitag1, NXP Hitag2



OEM Read/Write Module - HF Plus ISO14443A/B 13.56 MHz + NFC

- Read/Write Module without antenna
- TTL interface (UART)
- With external antenna available to achieve up to 8 cm reading distance
- Supports NXP Mifare (Ultralight), NXP DESFire, NXP Smart MX, Infineon SLE66CL160S/320P and NFC

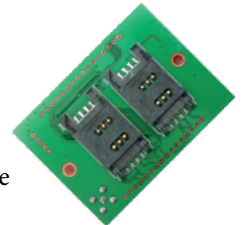

OEM Reader/Writer Multitag (ISO14443A/B + ISO15693)

- OEM Read/Write unit with integrated antenna
- Interface options: RS232 or RS485
- Reading distance up to 8 cm
- Supports ISO14443 A/B (including NXP Mifare family) tags and ISO15693 tags



OEM Read/Write Module ISO15693 13.56 MHz

- Read/Write Module without antenna
- TTL interface
- With external antenna available to achieve up to 18 cm reading distance
- Supports ISO15693 tags like NXP I-Code SLI and TI Tag-it HFI



Mini OEM Reader/Writer Multitag (ISO14443A/B + ISO15693)

- Mini OEM Read/Write unit with separate PCB antenna
- Interface options: TTL, RS232 or RS485
- Reading distance up to 10 cm
- Supports ISO14443 A/B (including NXP Mifare family) tags and ISO15693 tags



Ready-To-Use Readers

More information on page 11





RFID System Bluebox



The iDTRONIC Professional RFID System Bluebox is for professional users, offering solutions in LF, HF, UHF and 2.45GHz Active RFID

technology. The high-quality Bluebox RFID readers and antennas are available for Short-Range, Mid-Range & Long Range applications. All com-

ponents have robust CE approved IP65 housing / connection protection and different interface options including Ethernet and Profibus. Firmware

UHF 860-960 MHz

Type	USB encoder	Controller with integrated antenna	Controller mid range with 1 antenna port	Antenna mid range
Dimensions controller	80 x 160 x 40 mm	80 x 120 x 55 mm	80 x 120 x 55 mm	-
Antenna / dimensions antenna	Built in	Built in	External	300 x 300 x 50 mm
Protection class	IP65	IP65	IP65	IP65
Temperature range	-10 ... +65 °C	-10 ... +65 °C	-10 ... +65 °C	-10 ... +65 °C
Voltage supply	5 V DC via USB	10 - 27 V DC	10 - 27 V DC	-
Digital input	-	2	2	-
Digital output	-	2	2	-
3 LEDs + buzzer	-	Yes	Yes	-
Reading / writing distance	Up to 80 cm	Up to 80 cm	Up to 3 m	Up to 3 m
Certification	CE	CE	CE	CE
Interface options	USB	RS232 / RS485, Ethernet, Profibus, CAN Bus	RS232 / RS485, Ethernet, Profibus, CAN Bus	SMA + cable 3 m

Type	Controller long range with 4 antenna ports	Antenna long range circular	Antenna long range linear
Dimensions controller	120 x 220 x 80 mm	-	-
Antenna / dimensions antenna	External	250 x 250 x 50 mm	250 x 250 x 50 mm
Protection class	IP65	IP65	IP65
Temperature range	-10 ... +65 °C	-10 ... +65 °C	-10 ... +65 °C
Voltage supply	10 - 27V DC		
Digital input	2		
Digital output	2		
3 LEDs + buzzer	Yes		
Reading / writing distance	Up to 10 m	Up to 10 m	Up to 10 m
Certification	CE	CE	CE
Interface options	RS232 / RS485, Ethernet, Profibus, CAN Bus	SMA + cable 3 m	SMA + cable 3 m



RFID System Bluebox



upgrades and configurations are easily possible. All Bluebox Controllers come with detailed Demo SW and full SDK. The Professional RFID system

Bluebox can be used in applications like Industrial, Warehouse, Asset tracking, Laundry and Identification.



HF 13,56 MHz

Type	USB encoder	Controller with integrated antenna	Controller mid range with 1 antenna port	Controller mid range with 2 antenna ports
Dimensions controller	80 x 160 x 40 mm	80 x 120 x 55 mm	80 x 120 x 55 mm	80 x 120 x 55 mm
Antenna / dimensions antenna	Built in	Built in	External	External
Protection class	IP65	IP65	IP65	IP65
Temperature range	-10 ... +65 °C	-10 ... +65 °C	-10 ... +65°C	-10 ... +65°C
Voltage supply	5 V DC via USB	10 - 27 V DC	10 - 27 V DC	10 - 27 V DC
Digital input	-	2	2	2
Digital output	-	2	2	2
3 LEDs + buzzer	-	Yes	Yes	Yes
Reading / writing distance	Up to 12 cm	Up to 15 cm	Up to 30 cm	Up to 3 m
Certification	CE	CE	CE	CE
Interface options	USB	RS232 / RS485, Ethernet, Profibus, CAN Bus	RS232 / RS485, Ethernet, Profibus, CAN Bus	SMA + cable 3 m

Type	Panel antennas	Cylindrical antennas	Cylindrical reader	On-metal antenna	Controller long range with 1 antenna port	Antenna long range
Dimensions controller	-	-	M30	-	80 x 120 x 55 mm	-
Antenna / dimensions antenna	30 x 45 mm, 80 x 80 mm, 200 x 200 mm, 210 x 450 mm	M18 x 90 mm, M30 x 78 mm	M 30 x 78 mm	70 x 70 mm	External	300 x 300 x 50 mm
Protection class	IP65	IP65	IP65	IP65	IP65	IP65
Temperature range	- 10 ... +65 °C	- 10 ... +65 °C	- 10 ... +65 °C	- 10 ... +65 °C	- 10 ... +65 °C	- 10 ... +65 °C
Voltage supply	-	-	12V DC	-	10 - 12V DC	-
Digital input	-	-	-	-	2	-
Digital output	-	-	-	-	2	-
3 LEDs + buzzer	-	-	-	-	Yes	-
Reading / writing distance	Up to 30 cm	Up to 13 cm	Up to 10 cm	Up to 7 cm	Up to 80 cm	Up to 80 cm
Certification	CE	CE	CE	CE	CE	CE
Interface options	3 PIN metal connector + cable 1.5 m	3 PIN metal connector + cable 1.5 m	RS232 + cable 1.5 m	3 PIN metal connector + cable 1.5 m	RS232 / RS485, Ethernet, Profibus, CAN Bus	Cable 1.5 m



RFID System Bluebox



LF 125 kHz

Type	USB encoder	Controller with integrated antenna	Controller mid range with 1 antenna port	Controller mid range with 2 antenna ports	Panel antennas
Dimensions controller	80 x 160 x 40 mm	80 x 120 x 55 mm	80 x 120 x 55 mm	80 x 120 x 55 mm	-
Antenna / dimensions antenna	Built in	Built in	External	External	200 x 200 mm
Protection class	IP65	IP65	IP65	IP65	IP65
Temperature range	-10 ... +65 °C	-10 ... +65 °C	-10 ... +65°C	-10 ... +65°C	-10 ... +65°C
Voltage supply	5 V DC via USB	10 - 27 V DC	10 - 27 V DC	10 - 27 V DC	-
Digital input	-	2	2	2	-
Digital output	-	2	2	2	-
3 LEDs + buzzer	-	Yes	Yes	Yes	-
Reading / writing distance	Up to 12 cm	Up to 15 cm	Up to 20 cm	Up to 20 cm	Up to 20 cm
Certification	CE	CE	CE	CE	
Interface options	USB	RS232 / RS485, Ethernet, Profibus, CAN Bus	RS232 / RS485, Ethernet, Profibus, CAN Bus	RS232 / RS485, Ethernet	3 PIN metal connector + cable 1.5 m

Type	Controller Mid Range with 1 antenna port	Panel antennas mid range	Controller long range with 1 antenna port	Controller long range with 4 antenna ports	Panel antennas long range
Dimensions controller	80 x 120 x 55 mm	-	120 x 220 x 80 mm	120 x 220 x 80 mm	-
Antenna / dimensions antenna	External	120 x 120 mm to 250 x 250 mm	External	External	240 x 240 mm to 480 x 600 mm
Protection class	IP65	IP65	IP65	IP65	IP65
Temperature range	- 10 ... +65°C	- 10 ... +65°C	- 10 ... +65°C	- 10 ... +65°C	- 10 ... +65°C
Voltage supply	10 - 27 V DC	-	10 - 27 V DC	10 - 27 V DC	-
Digital input	2	-	2	2	-
Digital output	2	-	2	2	-
3 LEDs + buzzer	Yes	-	Yes	Yes	-
Reading / writing distance	Up to 30 cm	Up to 30 cm	Up to 120 cm	Up to 120 cm	Up to 120 cm
Certification	CE	CE	CE	CE	CE
Interface options	RS232 / RS485, Ethernet, Profibus, CAN Bus	3 PIN metal connector + cable 1.5 m	RS232 / RS485, Ethernet, Profibus, CAN Bus	RS232 / RS485, Ethernet, Profibus, CAN Bus	SMA + cable 1.5 m

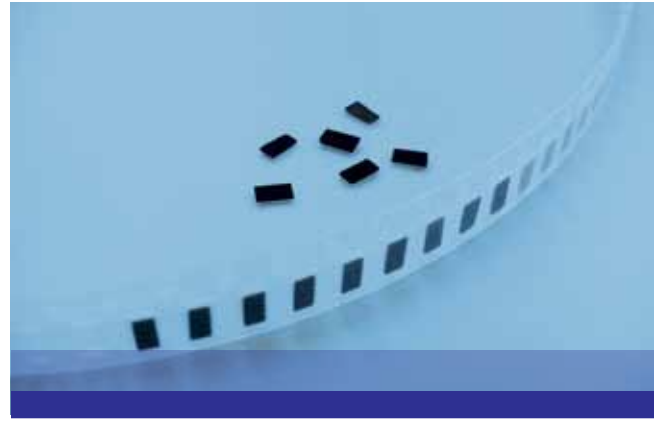

Passive RFID systems

schreiner
Group

muRata
Innovator in Electronics

Schreiner Group offers primarily customer specific tickets and labels. The transponders have chips included from world's leading suppliers.

Drawing on many years of joint development work with customers from various industries, Schreiner Group is able to offer a wide range of innovative RFID labels and transponders.

When designing RFID labels, the main objective of Schreiner is to meet the requirements and wishes of their customers. This results in custom-tailored solutions regarding shape, printing, durability, adhesion, chip technology or technical functionality. Thanks to their comprehensive system know-how and long-standing experience Schreiner Group will create an RFID solution exactly suiting your needs – including multifunctional performance features, if you wish.

Special requirements such as tamper evidence, authenticity protection, personalization, encoding, access passwords – almost anything is possible. A combination with a printed solution (barcode, cleartext, etc.) can be created as well.

Magicstrap, RFID tag in UHF band

Murata MAGICSTRAP® is an innovative RFID module with a wide range of RF features.

- Incorporates an industry standard IC
- Antenna filter covering worldwide RFID frequencies (EU, US and Japan)
- Antenna matching circuit
- ESD protection
- Compliant to EPC global Class1Gen2
- Ultra small package (3.2 x 1.6 x 0.55 mm typ.) ensuring high durability
- Supports wide frequency range from 860 MHz to 960 MHz, covering all globally relevant UHF frequency bands with one single design
- Impedance transformation function for more accurate matching with various antenna designs.
- 4 different variants available, which allow perfect matching to antenna impedance
- Inductive coupling with antenna even through non-conductive adhesive
- Wide mechanical mounting tolerance for assembly into RFID tag or inlay
- Internal 512 bit user memory available
- Product is subject to certain conditions, please contact your sales contact.



Passive RFID systems



M24LR64 64 Kbit EEPROM with password protection & dual interface: 400 kHz I²C serial bus & ISO 15693 RF protocol at 13.56 MHz

The M24LR64 is an electrically-erasable memory (EEPROM) that can be accessed either from a wired I²C interface, or from an industry-standard RF interface which does not require any on-board power to operate. Using the M24LR64 for program or data storage provides extra flexibility for customers by allowing software and parameter updates to be applied remotely during the entire product lifetime.

I²C interface

- Two-wire I²C serial interface supports 400 kHz protocol
- Single supply voltage: – 1.8 V to 5.5 V
- Byte and Page Write (up to 4 bytes)
- Random and Sequential Read modes

Contactless interface

- ISO 15693 and ISO 18000-3 mode 1 compliant
- Internal tuning capacitance: 27.5 pF
- 64-bit unique identifier (UID)
- Read Block & Write (32-bit Blocks)

Memory

- 64 Kbit EEPROM organized into:
 - 8192 bytes in I²C mode
 - 2048 blocks of 32 bits in RF mode
- More than 1 Million write cycles

ZWIR4121

Passive transponder with EEPROM and temperature sensor

The ZWIR4121 is a fully integrated, 13.56 MHz, ISO15693-compliant passive transponder IC with an on-chip temperature sensor and wireless initialization capability. With on-chip temperature sensor, and EEPROM for time and temperature logging, the ZWIR4121 is designed to increase the degree of automation and safety in logistics and transportation of perishable goods or produce.

The ZWIR4121 was designed with low component count in mind. Due to the on-chip tank capacitor, the ZWIR4121 only requires one external coil to communicate with a reader unit. A battery supply (1.5 V) is required for data logging when the IC is removed from the field.

The additional I²C bus connection allows adding an external sensor to the ZWIR4121.

- Wireless initialization capability
- Communication range up to 1 meter
- 8 kbits EEPROM (720 temperature data)
- Internal real time clock
- Internal temperature sensor
- Interface to external humidity sensor
- Multi level password protection
- 8 different log modes
- Power supply: 1.1 – 1.5 V
- Idle current: < 100 μA
- Timer on: <1.5 μA



Ready to use readers

FREE2MOVE



Gemia™ ISO 18000-6c (EPC Gen2) reader

Gemia™ is a mobile power-efficient RFID reader, that combines built-in directional antenna, a low power Bluetooth® interface and a built-in battery for 10 hours effective operation into a light, small form-factor unit. Gemia™ can be used with any host supporting Bluetooth® serial port profile (SPP). Its form-factor makes it ideal for desktop, point-of-sale and add-on to handholds alike. Along with the Gemia™, Free2move offers accessories for fixing it to popular industrial handholds such as Opticon's PHL8000 series and the Psion Teklogix Ikon 7505. By having its own battery, Gemia™ does not drain power from the host handheld. Paired to a computer, it can also be used separately, e.g. as a separate handheld or clipped to a belt. A desktop stand is also available.

- Anti-collision technology supports reading 25 tags per second
- Rugged enclosure, IP54, drop tested at 1 meter
- Up to 60 cm read range
- 862 to 955 MHz operation frequency (software configurable to regulatory domain)
- Rechargeable lithium Ion battery
- API support

Evaluation kits with reader, tags and software examples are available.

iDTRONIC has a big portfolio of RFID readers and reader-writers for different usage scenarios and applications.

- Desktop reader/writer with USB interface.
- Pen stick reader/writer with USB interface.
- Mobile reader with rechargeable battery for up to 16000 readings before recharging with USB and Bluetooth interface.
- Mobile terminal with ARM 9 processor that can be programmed in C++ or C# for customer application. The terminal has a rechargeable battery and IP54 protection. Communication to host units is done over USB.
- Mobile terminal with rechargeable battery and USB or WiFi connection to host units. The terminal is running Windows CE on an ARM 9 processor and has an integrated slot for a SDIO RFID reader.
- SDIO readers for different RFID standards that can be plugged into any PDA or other mobile terminal.

For more information about the different readers please contact nearest Rutronik office.



Passive RFID transponders – Overview

ISO and Hybrid Cards

Available 125 kHz, 13.56 MHz and UHF IC technologies.
Cards can be customized with different personalization and encoding options.



Smartlabels and Tickets

Adhesive Labels 13.56 MHz and UHF, CD/DVD Labels and Paper Tickets.



Special Tags

Glass Transponders, On-metal Tags, On-metal Labels,
High Temperature Tags, UHF Hard Tags, Nail Tags,
Animal Tags (134 MHz), etc.



Keyfobs and Wristbands

The Keyfobs and Wristbands are all waterproof and can be printed and personalized.



Disctags

These Tags are available with different diameters, with printing and with/without centre hole.





F2M07 reader



F2M08 tags

Active RFID system

FREE**2**MOVE

The name RFIDS™ stands for Radio Frequency IDentification & Sensing. RFIDS™ makes it easy to build complete active RFID and wireless sensor systems. RFIDS™ offers scalability from low cost active tags to advanced sensor tags. Advanced RFIDS™ tags are used for telemetry and environment control, or for logging sensor data into the tag's memory when outside of reader range. RFIDS™ tags may also offer user interface features like light and sound indicators, displays and function buttons. Furthermore, RFIDS™ is designed for ultra low power consumption, high security and robust performance even in metal-rich environments. By default, standard RFIDS™ products make use of the licence free 2.4 GHz ISM band. The advantage of 2.4 GHz is primarily consistent regulation throughout the world. Custom implementations of RFIDS™ in other frequencies such as 433 MHz are also possible.

Evaluation kits

Different types of evaluation kits is available to make it easy to perform demonstrations, site surveys, lab-work education and application development. The kits include reader, power supply and different types of sensors depending on kit version.

F2M07 – RFID readers

- Addresses up to 300 tags per second
- IP54 classified enclosure
- Connector for external antennas
- Communicates via RS232, RS422, Bluetooth®, LAN
- Easy-to-use host protocol

F2M08 - RFID tags

- Small size
- Several years of operating time
- IP classified enclosure
- Replaceable battery
- Remote supervision of onboard battery
- Available with different types of sensors:
 - Identification
 - Temperature sensing/logging
 - Switch tag with asset locking
- Pick-to light for location of assets
- Secure wristband tag
- Customizable



Software for ISM-band RF chips and modules

Public standard protocols, like ZigBee™ and Bluetooth®, make sense if you need to be compatible to other existing devices in the field.

If you have control about all of your communication partners, an open source or company owned protocol, like M-One or MiWi™, is cheaper and could be the more smart solution to fulfil your requirements.

To meet your requirements (power consumption, timings, pairing, security,...) by 100%, you need to invest a little bit more time to adjust an open-source proprietary protocol, like Gazell.

In any case you don't need to build up a protocol by yourself. Rutronik has a wide range of ready to use solutions available. Let us know your requirements as more detailed as possible to get the best proposals.

Pre qualified or certified modules make the end qualification/certification less expensive for the final product. The integrator of the module has to follow the manufactures guidelines regarding installation in the final product and make some tests to fulfil the requirements before the product is put on the market. Normally the final test includes Radiated Spurious Emission, Safety / RF Exposure and EMC.

Product	Type of software / application	Available from
6LoWPAN	IPv6 over IEEE 802.15.4 networks / sensor networks	ZMDI
ANT™ and ANT+	Point-to-point, star, mesh / sensor networks	Dynastream, Nordic Semiconductor
Bluetooth®	Point-to-point, star (Piconet) / connect to standard products	Free2move, Fujitsu, Nordic Semiconductor
Gazell™	Point-to-point, star / remote control, PC peripheral	Nordic Semiconductor
M-One	Mesh network	Telit
MiWi™	Mesh and point-to-point	Microchip
S-One	Point-to-point, star	Telit
W-Mbus	Wireless meter bus EN 13757	Telit
WLAN	IEEE 802.11 standard	Fujitsu, Microchip, Silex
ZigBee®	Mesh	Renesas, STMicroelectronics, Telit
PF4CE	Radio Frequenz for consumer electronics (Remote Control)	Renesas, STMicroelectronics, Telit
RFDP8	RFID, Esn, Logic Switch, Serial VART	RFDigital

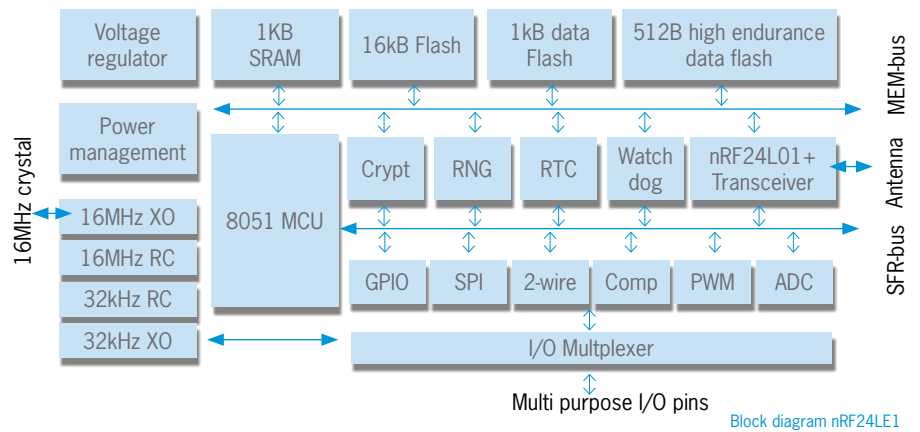

ISM/SRD



Few external components result in low systems cost and small size

- Made for high volume production
- FSK or GFSK modulation for efficient and reliable communication
- Low voltage operation and extensive power down features

Part number	Description	Physical peripherals	Package
nRF24LE1	2.4 GHz Transceiver	nRF24L01+ transceiver with 8051 MCU, 7-31 I/O Ports	24/32/48 pin
nRF24L01+	2.4 GHz Transceiver	Enhanced ShockBurst, MultiCiver, Link Layer Protocol	20 pin / 4x4 mm
nRF24LU1+	2.4 GHz Transceiver	USB Microcontroller and Flash Memory	32 pin / 5x5 mm
nRF24AP2	2.4 GHz Transceiver	Embedded ANT protocol for personal area networks (PAN)	32 pin / 5x5 mm
nRF24AP2-USB	2.4 GHz Transceiver	Embedded ANT protocol with USB interface	32pin/5x5 mm
nRF24Z1	2.4 GHz audio streaming Transceiver	I2S, S/PDIF, SPI, QoS engine, 4Mbit/s transceiver	36 pin / 6x6 mm
nRF9E5	433/868/915 MHz Transceiver	8051MCU 4 ch ADC, ShockBurst	32 pin / 5x5 mm
nRF905	433/868/915 MHz Transceiver	ShockBurst	32 pin / 5x5 mm

nRF24LE1

Ultra low power wireless system-on-chip solution

- Fully featured ultra low power nRF24L01+ 2.4 GHz transceiver core
- Enhanced ShockBurst™ hardware link layer
- 250 kbps, 1 Mbps and 2 Mbps on-air data rate options
- Air compatible with nRF24L01, nRF24L01+, nRF24LU1, and nRF2401A, -02, -E1 and -E2
- Enhanced 8-bit 8051 compatible microcontroller
- 32-bit multiplication-division unit, AES encryption/decryption accelerator
- 16 kb Flash memory, 1 kb data Flash memory, 512 b high-endurance data Flash memory
- 1 kb SRAM plus 256 b of IRAM
- Low power 16MHz crystal and RC oscillators, ultra low power 32 kHz crystal and RC oscillators
- Flexible real-time counter and three 16-bit timers/counters
- Ultra low power analog comparator for system wake-up
- Digital interfaces including: SPI master/slave, 2-wire master/slave and UART
- 2-channel PWM
- Programmable resolution ADC: 6, 8, 10 or 12-bits
- Random Number Generator based on thermal noise
- Supports the Nordic nRFProbe hardware debugger
- Programmable generic I/O pins
- Three package options:
 - 4x4 mm 24-pin QFN (7 Generic I/O pins)
 - 5x5 mm 32-pin QFN (15 Generic I/O pins)
 - 7x7 mm 48-pin QFN (31 Generic I/O pins)

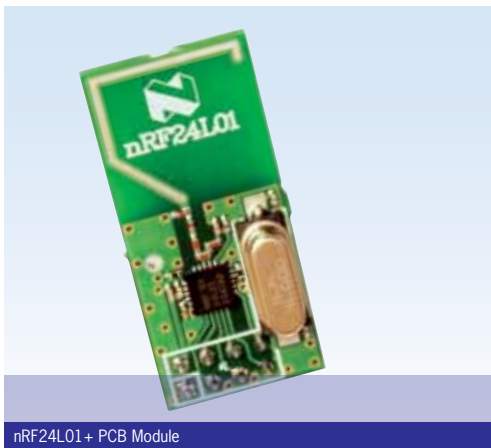

nRF24L01+ PCB Module

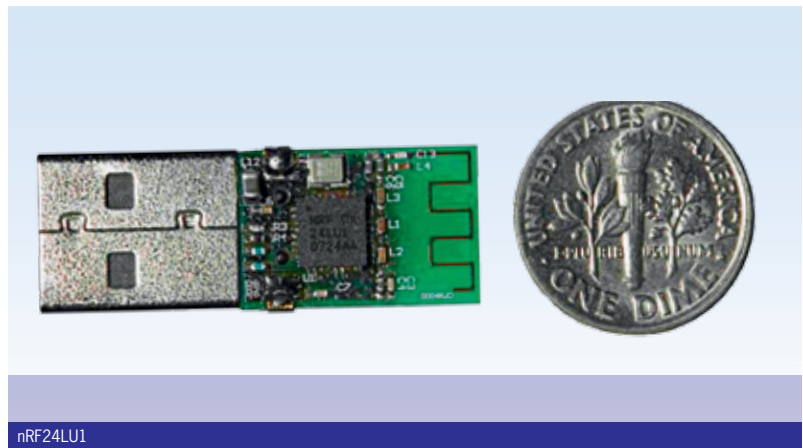

nRF24LU1

ISM/SRD



nRF24L01+

- Drop in compatible with the nRF24L01
- Ultra low power operation and advanced power management
- Enhanced ShockBurst™ hardware link layer
- Automatic packet assembly (Preamble, Address and CRC)
- Dynamic payload length
- Selective auto acknowledgement with payload
- Auto retransmit
- Fully air compatible with Nordic nRF2401A, 02, E1 and E2 at 1 Mbps and 250 kbps air data rates
- Compact 20-pin 4x4mm QFN package

nRF24LU1+

- nRF24L01 compatible RF transceiver
- Enhanced ShockBurst™ hardware link layer
- Air compatible with nRF24L01, nRF2401A, 02, E1 and E2
- Full speed USB 2.0 compliant device controller
- Enhanced 8-bit 8051 compatible microcontroller
- 6 general purpose digital input/output pins
- Hardware SPI slave and master, UART
- AES encryption/decryption co-processor
- Supports firmware upgrade over USB
- Compact 32-pin 5x5mm QFN package

Production ready reference design

nRF24LU1-DONGLE

The nRF24LU1-DONGLE is a production-ready reference design with the nRF24LU1. It integrates the nRF24LU1, a low-cost PCB antenna, crystal and required passives in a compact 12 x 32mm form factor. The design is FCC, ETSI and USB compliant.

nRF905, nRF9E5

Single chip 433/868/915 MHz transceivers with 10 dBm output power and -100 dBm sensitivity for long range applications.

nRF9E5

with built in 8051 microcontroller, 4 input 10 bit A/D converter, serial interface for external EEPROM, programmable PWM, timers and I/O ports etc.

- ShockBurst to reduce power consumption
- 1.9 – 3.6 V supply voltage
- CRC computation in RX and TX
- GFSK modulation
- Address match and stripping in RX
- Multi channel



nRFgo Starter Kit



nRFgo Development Kit

ISM/SRD



nRFgo Starter Kit

The nRFgo Starter Kit is the core of the nRFgo evaluation and development platform for Nordic ultra low power radios. Used in conjunction with any nRFgo compatible development kit, the Starter Kit enables engineers to perform quick evaluation, prototyping and firmware development. The kit includes two motherboards, a display extension module, patch cables and a CD with nRFgo Studio PC application and documentation. The motherboards include a standardized socket for Nordic radio modules. Radio modules are not included in the kit, but provided separately as part of product specific nRFgo compatible development kits.

nRFgo Development Kit for nRF24LE1

Enabling single chip ultra low power wireless applications.

The nRF24LE1 Development Kit comes in three variants, the nRF24LE1-F16Q24-DK for the 24-pin 4x4mm variant, the nRF24LE1-F16Q32-DK for the 32-pin 5x5mm variant, and the nRF24LE1-F16Q48-DK for the 48-pin 7x7mm variant. These kits used in conjunction with the nRFgo Starter Kit enable users to perform evaluation, testing, prototyping, firmware development and debugging on the nRF24LE1. The kit includes three nRFgo compatible radio modules, two of them with PCB antennas and one with an SMA connector for use with external antennas or in a closed loop set-up. The CD contains a complete Software Development Kit (SDK) as well as documentation.

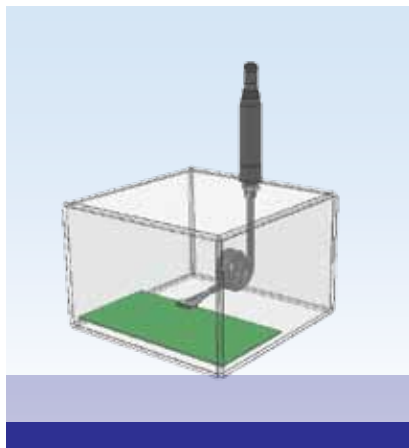

ISM/SRD



RF Digital is an approved Nordic Semiconductor module provider.

RF Digital manufactures a wide range of ready-to-use transmitter, receiver and transceiver RF modules, all of which are based on the Nordic Semiconductor ICs. Depending on the application, there is the option of the **radio-only modules**, the **transceiver modules** with built-in microcontroller and the **application modules**.

All modules works on the open 2.4 GHz ISM band with dBm output power and -94 dBm receiver sensitivity. Multi-frequency modules with 125 channels. Maximum data rate over-the-air is 2 Mbps.

RFDANT

The RFDANT is RF Digital's Worldwide Patent Pending Radio Inside Antenna product.

The entire radio transceiver is mounted inside the antenna enclosure, so there is no loss of RF power to the antenna from the module, and results in the most effective power transfer ratio possible.

The radio being inside of the antenna and outside the enclosure allows for more room inside the enclosure for the designers application electronics.

Minimal interference with the internal electronics of the enclosure results in better range and performance of the wireless system.

Logic level signals are used through an unshielded cable (not coax) to the RFDANT, which can be run for long distances without any loss to the performance of the wireless transceiver.

By the antenna and module being fully outside allows for easy retrofit of nearly any product due to it not consuming any internal space inside the enclosure, drill a hole and screw it in, add a nut inside to secure it and wire the logic level signals to your electronics. Mount on metal or plastic enclosures with no worry about ground effects.

Stable Antenna Pattern providing substantial, well-distributed, passive-gain for transmit and receive, results longer repeatable range from your wireless system.

The nRF24LE1 from Nordic Semiconductor is mounted inside the antenna.

With RFDP8 firmware:

- RFD21743 RFDANT CE and FCC (50% duty cycle)
- RFD21742 RFDANT CE (100% duty cycle)

Without firmware:

- RFD21741 RFDANT CE

The RFDANT cable has an 11-pin connector with the same functions as the nRF24LE1 modules.

Evaluation boards with the different parts are available:

- RFD21773 Evaluation board with RFD21743
- RFD21772 Evaluation board with RFD21742
- RFD21764 Evaluation board with RFD21741 for Nordic Semiconductor nRFgo kit



RFD21733



RFD21735



RFD21736

ISM/SRD



Modules with built in ready-to-use RFDP8 application protocol

RF Digital's RFDP8 proprietary patent-pending frequency agility protocol operates in the internationally accepted 2.4 GHz band. The RFDP8's leading-edge advanced algorithm is not burdened by a heavy-weight stack as is Bluetooth®, ZigBee®, WLAN and other protocols.

The RFDP8 protocol is highly robust and effective where there is a need to penetrate through a high saturation of RF noise which is common in nearly all environments today. It is especially effective and can easily coexist in heavy WiFi environments. The protocol strategically changes channels frequently to deliver its payload to the destination device reliably, yet not too excessively as to demand too much internal processing power which allows it to run with a very low current consumption profile and fast start up times allowing substantial flexibility with implementation.

The RFDP8 protocol reduces the amount of on-air traffic and unnecessary chatter due to its unique and highly efficient design, which does not require bilateral registration and association as do many other technologies today. The RFDP8 does not require ack-nacks to complete a packet delivery, it's unique technique of packet delivery, recovery and correction allows it to work as a one-way link, hence drastically simplifying users' applications which always results in more a robust wireless system.

The RFDP8 protocol delivers a highly robust method of delivering user data from point to point, point to multi-point or multi-point to multi-point, transmitter-receiver, transceiver, serial or switch on/off data modes.

The protocol is designed to work seamlessly with RF Digital's hardware modules, the combination results in ultra long range at ultra low currents without concern for compliance approvals .

The RFDP8 protocol adds several dB of range gain passively through it's advanced data recovery technique which pulls valid data out of a noisy environment adding effective gain which results in more range, delivering the net result, which is a very robust wireless system.

All of this is built into the overhead of the RFDP8 protocol and RF Digital modules, so it's all done behind the scenes, allowing the user to focus on building their application and

Simply putting data into the radio device as a wireless pipe and easily receiving it on the other end.

- RFD21733 / RFD21735
SMT module (15x15 mm) with onboard chip antenna / antenna pad.
- RFD21737 / RFD21738
Evaluation board with RFD21733, internal antenna / external wire antenna, CE, ETSI and FCC approved
- RFD21739
Evaluation board with RFD21735, antenna connector
- RFD21736
Evaluation board to be used with nRFgo development kit from Nordic Semiconductor.

All evaluation boards (except RFD21736) with 12-pin header connector, I/O switches and LED's. Battery holder on backside of PCB.



RFD21731



RFD21734



Key fob

ISM/SRD



Radio only modules based on nRF24L01+

- RFD21711
With SMA antenna connector and 8-pin header connector.
- RFD21712
With antenna on PCB and 8-pin header connector.

Transceiver modules based on nRF24LE1

Complete ultra-low-power system-in-module with mixed signal flash microcontroller and advanced power management. No RF design required.

- RFD21731
SMT module (15x15 mm) with onboard chip antenna.
- RFD21732
Same as RFD21731 with onboard 32 kHz crystal.
- RFD21734
Same as RFD21732 but without antenna. Antenna pad for external antenna.

RFD21733 Keychain (KEYFOB)

Reference Design

This reference design provides all the details required to produce your own key-chain (key-fob) remote control transmitter using RF Digital's RFD21733 FCC, CE, ETSI Transceiver. Schematic, BOM, Gerber files for PCB fabrication and enclosure details and sources are all included.

There are three different configurations for the transmitter enclosure, you can have 1, 2 or 3 buttons.

With simple selection of a couple zero ohm jumpers on the board, you can easily choose between using the RFD21733 in its Mode 0 RFID transmitter mode or in its Mode 1, three input switch transmitter mode.

RFDP8 Module as Active RFID

MODE 0

In this mode, simply apply 1.9 to 3.6 VDC (typically 3V), and the RFD21733 and it will automatically transmit once every 2 seconds as an RFID transmitter. With every transmission it also sends its unique 32 BIT ESN (Electronic Serial Number).



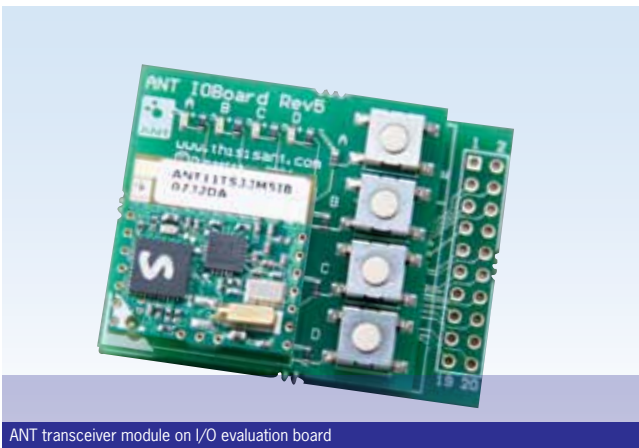

ANT transceiver module on I/O evaluation board



nRF24AP2

ISM/SRD



ANT

ANT is a 2.4GHz practical wireless networking protocol and embedded system solution specifically designed for wireless sensor networks (WSN) that require:

- Ultra low power (ULP)
 - runs on a coin cell for years of operation
- High resource optimization
 - fits into a compact sized memory
- Network flexibility and scalability
 - self-adaptive and capable of practical mesh
- Easy-to-use with low system cost
 - ANT operates independently with a single chip

Proven with millions of deployed nodes, ANT™ is perfectly suited for any kind of low data rate sensor network topology- from peer-to-peer or star, to practical mesh-in personal area networks (PAN), which are well suited for sport, fitness, wellness and home health applications. As well, ANT is a practical solution for local area networks (LAN) for homes and industrial automation applications.



ANT+, based on the ANT protocol, is the interoperability standard that facilitates the collection, automatic transfer and tracking of complete personal fitness and home health data. The established ANT+ device profiles ensure seamless communication between different company devices. Other features include automatic download, security and interference avoidance.

nRF24AP2-8ch and nRF24AP2-1ch

The nRF24AP2 is an advanced ultra low power single chip ANT solution ideal for coin cell powered wireless sensor applications. nRF24AP2-8ch ideally suits wireless sensors hubs, while nRF24AP2-1ch suits sensors.

Features

- Based nRF24L01+ 2.4GHz transceiver core technology
- Fully embedded enhanced ANT ultra low power wireless network protocol stack
- Scanning channel - for low latency applications
- High density node support - up to 80 nodes in close proximity
- Channel ID management - improves pairing efficiency
- Frequency agility mode - further improved co-existence performance
- As low as 14µA average current consumption
- 17mA max peak current
- Coin cell (watch) battery operation
- Supports simple to complex network topologies including: peer-to-peer, star, tree and practical mesh networks
- Broadcast, Acknowledged and Burst message types
- Supports both public and private (i.e. managed) networks
- Supports ANT+ implementations providing multivendor interoperability
- Simple synchronous/asynchronous serial host interface
- ANT channel combined message rate up to 190Hz (8byte data payload)
- Burst transfer rate up to 20kbps
- Low cost external ±60ppm 16MHz crystal
- On-chip ultra low power 32kHz crystal oscillator
- 1.9 to 3.6V supply voltage
- RoHS compliant 5x5mm 32-pin QFN package

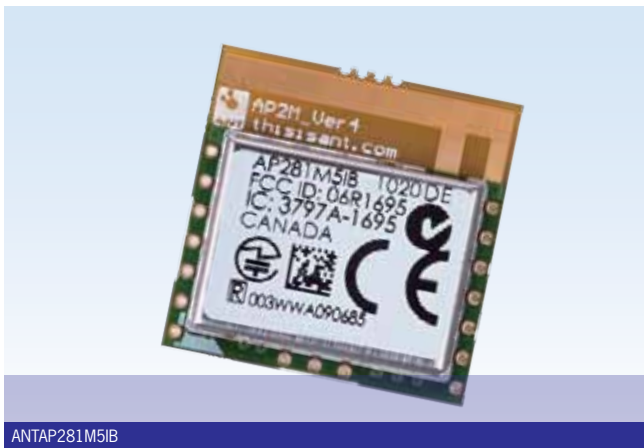

ISM/SRD



ANTAP281MxIB RF transceiver module with nRF24AP2-8ch chip

The ANT AP2 module is a drop-in module based on the reference design of nRF24AP2. An F antenna is integrated on the small-sized 20mm by 20mm board.

Fully-certified ANT RF modules enable fast time to market

The modules have been certified to comply with radio regulations or standards covering global markets including North America, Europe, Japan and Australia. The integrated modules ease the burden of extensive RF and antenna design, and regulatory compliance testing, which allows for quicker time to market.

ANTAP281M4IB is surface mountable for volume production.

ANTAP281M5IB is connectorized and ideal for evaluation and prototyping.

Features

- Simple sync/async serial interface
- Integrated F antenna
- On board 32.768 kHz crystal oscillator
- Up to 8 ANT channels
- 20mm x 20mm
- 1.9V to 3.6V supply voltage range
- -40°C to +85°C operating temperature
- RoHS compliant

ANTAP2DK1 development kit

The ANT development kit offers a comprehensive set of ANT modules, PC tools and resources to assist

- Evaluation of ANT as a practical, Wireless Sensor Network solution
- Design of ANT product prototypes and network demonstrations using ANT module and chip sets
- Evaluation of using SensRcore as an easy wireless sensor development platform, writing scripts and configuring modules
- Design of PC applications linking to ANT products and networks

ANT Development Kit provides

- Easy setup network demonstrations
- 2 x ANTAP281M5IB modules and 2 x ANT11TS33M5IB modules
- 2 x battery boards
- 2 x I/O boards
- 2 x USB interface boards
- 2 x CR2032 coin cells



SmartLEWIS™ PMA 7110

ISM/SRD



SmartLEWIS™ transmitters with microcontroller

PMA 71xx / PMA 51xx

The SmartLEWIS™ (Smart Low Energy Wireless Systems) MCU products contain a fully integrated VCO and integer N PLL synthesizer, a high efficiency power amplifier with selectable output power, an embedded 8051 microcontroller with 6k byte Flash and 10 General Purpose IOs. The integrated LF-Receiver enables wireless wake-up in battery operated applications with ultra-long-lifetime or even contactless configuration of the device. A comprehensive software function library with high level commands in ROM allows easy and fast time to market development and helps reducing the user code size and as such expensive flash memory size. The software function library provides many powerful functions like AES-encryption and EEPROM emulation. The SmartLEWIS™ MCU includes an advanced power control system making this family ideal for battery operated applications where low current consumption is necessary.

- Multiband (315/434/868/915 MHz) with ASK/FSK modulation
- TDA 5150, multiband, multichannel with ASK, FSK and GFSK modulation.
- I²C and SPI interface
- 10 bit ADC with 3 differential input channels
- Embedded temperature and supply voltage sensors
- Supply voltage range from 1.9V up to 3.6V
- Up to +10 dBm output power
- PMA 51xx with extended temperature range and automotive qualification

Single-channel, transmitters

TDK 510x, TDK 511x, TDA 711x

The devices contain a fully integrated PLL synthesizer and a high efficiency power amplifier to drive a loop antenna. A special circuit design and a unique power amplifier design are used to save current consumption and therefore to save battery life. Additionally, features like a power down mode, a low power detect, a selectable crystal oscillator frequency and a divided clock output are implemented. The devices are offered in TSSOP-16 and TSSOP-10 package variants. If your application allows for reduced requirements (e.g. limited temperature range), Infineon offers with its TDA 71xx(F) family high quality transmitter products at low cost dedicated for non automotive applications.

- Voltage supply 2.1V to 4.0V
- Two power versions:
 - TDK 510x(F) - ASK/FSK Transmitter Family for Low and Medium Power (+2 dBm .. +5 dBm)
 - TDK 511x(F) - ASK/FSK Transmitter Family for HighPower (+10 dBm)
 - TDA 71xx(F) - ASK/FSK Transmitter dedicated for non-automotive applications



Smart Lewis™ TDA 5240

ISM/SRD



Multi-channel, SmartLEWIS™ receiver

TDA 5230/TDA 5231

The TDA 5230/TDA 5231 series is a family of autonomous ASK/FSK receivers for the frequency bands 302–320MHz, 433–450MHz and 865–870MHz. A fully integrated RF synthesizer offers multi-channel capability. The digital base-band features fast symbol clock recovery based on a digital PLL plus automatic extraction of telegrams from run-in data. The data telegram can be screened for IDs before being stored in a FIFO data buffer. Autonomous self-polling reduces power consumption because it offloads the host in the receiver application. The device can switch between two configurations.

- Power down mode with very low supply current (typically 1 μ A)
- Low supply current (< 8mA active mode, < 50 μ A self polling mode)
- Two supply voltage ranges possible: 3.3 V \pm 10% or 5 V \pm 10%

SmartLEWIS™ RX+ family

TDA 5240/TDA 5235/TDA 5225

The new family of SmartLEWIS RX+ receivers combines long range, low energy consumption, high sensitivity and flexible adaption to customer requirements in a single package.

- Multi-band (315 MHz, 434 MHz, 868 MHz, 915 MHz bands), multi-channel
- Multi-protocol handling
- Integrated LNA
- One crystal frequency for all supported frequency bands
- Integrated IF-filter but also possible to use optional external filter

- Low supply current (0.8 μ A in power down, 12 mA in run mode)

- Digital RSSI peak detector
- On-chip temperature sensor

Additional TDA 5240/ TDA 5235 features

- High sensitivity
 - Typ. -118 dBm for FSK
 - Typ. -116 dBm for ASK
- Autonomous receiver mode
- Up to 4 (TDA 5240)/2 (TDA 5235) parallel parameter sets and up to 12 different frequency channels (TDA 5240 only)
- Several embedded encoding and modulation schemes

TDA 520x

The TDA 520x series is a family of ASK receivers for the frequency bands 308–312 MHz, 343–347 MHz, 433–435MHz and 868–870 MHz.

- Integrated VCO and PLL synthesizer
- RF input sensitivity \leq 107 dBm
- Limiter with RSSI generation
- Supply voltage 5 V \pm 10%

TDA 521x/TDA 5220/TDA 5221

The TDA 521x/TDA 5220/TDA 5221 series is a family of ASK/FSK receivers for the frequency bands 300–340 MHz, 400–440 MHz, 810–870 MHz and 915 MHz.

- Integrated VCO and PLL synthesizer
- Limiter with RSSI generation
 - Switchable comparator
 - Switchable peak detector (TDA 5220/21 only)
- Supply voltage 5 V \pm 10%



ISM/SRD



TDA 525x family

The transceiver IC family are low power consumption single chip FSK/ASK transceivers for half duplex communication in the 315 MHz, 434 MHz, 868 MHz and 915 MHz bands.

The IC need only a few external components and contain power amplifier, LNA with AGC, I/Q limiters with RSSI generation, integrated VCO and PLL synthesizer and a tuneable crystal oscillator.

- Low supply current
- Supply voltage range 2.1 – 5.5 V
- I²C/3-wire microcontroller interface
- Transmit power up to +13 dBm
- Sensitivity ≤ 109 dBm

Type		Description
Transmitter	TDK 510x /F	ASK/FSK Transmitter family for low power (2 - 5 dBm), temperature range -40°C - 125°C
	TDK 511x /F	ASK/FSK Transmitter family for high power (10 dBm), temperature range -40°C - 125°C
	TDA7100	ASK/FSK Transmitter family for low power (2 - 5 dBm), temperature range -20°C - 70°C
	TDA711x /F	ASK/FSK Transmitter family for high power (10 dBm), temperature range -40°C - 85°C
SmartLEWIS™ TX	TDA 5150	ASK/FSK Transmitter, multi-channel, multi-band, multi-power
SmartLEWIS™ MCU	PMA 5105	ASK/FSK Transmitter with embedded 8051 Microcontroller, temperature range -40°C - 125°C
	PMA 5110	ASK/FSK Transmitter with embedded 8051 Microcontroller and LF receiver, temperature range -40°C - 125°C
	PMA 7105	ASK/FSK Transmitter with embedded 8051 Microcontroller, temperature range -40°C - 85°C
	PMA 7106	ASK/FSK Transmitter with embedded 8051 Microcontroller and 10-bit ADC, temperature range -40°C - 85°C
	PMA 7107	ASK/FSK Transmitter with embedded 8051 Microcontroller and 125kHz LF Receiver, temperature range -40°C - 85°C
	PMA 7110	ASK/FSK Transmitter with embedded 8051 Microcontroller, 10-bit ADC and 125kHz LF Receiver, temperature range -40°C - 85°C
Receiver	TDA 520x	ASK Receiver family, temperature range -40°C - 85°C
	TDA 521x	ASK/FSK Receiver family, temperature range -40°C - 105°C
	TDA 522x	ASK/FSK Receiver family with switchable peak detector, temperature range -40°C - 105°C
	TDA7200	ASK/FSK Receiver family with switchable peak detector, temperature range -20°C - 70°C
	TDA7210 /V	ASK/FSK Receiver family, temperature range -40°C - 85°C, TSSOP and VQFN package
SmartLEWIS™ RX	TDA 5230/31	Receiver family with digital baseband processing, multi-channel, temperature range -40°C - 105°C
SmartLEWIS™ RX+	TDA 5225	High Sensitivity Receiver, multi-channel, temperature range -40°C - 105°C
	TDA 5235	High Sensitivity Receiver with digital baseband processing, single channel, temperature range -40°C - 105°C
	TDA 5240	High Sensitivity Receiver with digital baseband processing, multi-channel, temperature range -40°C - 105°C
Transceiver	TDA 525x	ASK/FSK Transceiver family, single-channel, temperature range -40°C - 85°C
	TDA7255V	ASK/FSK Transceiver family, single-channel, VQFN package, temperature range -40°C - 85°C
SmartLEWIS™ TRX	TDA 5325	High Sensitivity Transceiver, multi-channel
	TDA 5340	High Sensitivity Transceiver with digital baseband processing, multi-channel



MRF49XA

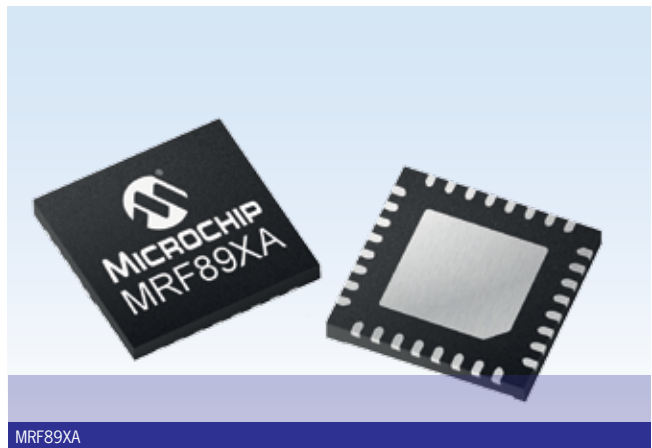

MRF89XA

ISM/SRD



Microchip provides sub-GHz radio frequency solutions which complement the PIC family of microcontrollers.

These products provide a flexible, cost effective platform to create the optimum wireless products and solutions for the application.

MRF49XA

MRF49XA is a fully integrated Sub-GHz RF transceiver supporting the 433/868/915MHz ISM frequency band. The MRF49XA supports FSK modulation with FHSS capability and is ideal for two-way, short-range wireless applications.

- Low current consumption, typically:
 - 11 mA in RX mode
 - 15 mA in TX mode
 - 0.3 μ A in Sleep mode
- RF output power of +7 dBm
- FSK modulation with FHSS capability
- Differential RF input/output
- Analog and digital RSSI output
- 4-wire SPI-compatible interface
- 16-bit transmit FIFO, two 8-bit TX registers
- Operating voltage 2.2 – 3.8 V
- Supports MiWi™ and MiWi P2P protocols

MRF89XA

The MRF89XA is a single chip, multi-channel FSK/OOK transceiver capable of operating in the 863–870 MHz and 902–928 MHz license-free ISM frequency bands, as well as the 950–960 MHz frequency band. The low-cost MRF89XA is optimized for very low power consumption (3 mA in Receiver mode). It incorporates a baseband modem with data rates up to 200 kb/s. Data handling features include a 64-byte FIFO, packet handling, automatic CRC generation and data scrambling. Its highly integrated architecture allows for minimum external component count while still maintaining design flexibility.

- Low current consumption, typically:
 - 3 mA in RX mode
 - 25 mA @+10 dBm in TX mode
 - 0.1 μ A in Sleep mode (2 μ A max.)
- RF output power of +12.5 dBm
- FSK and OOK modulation
- Single ended RF input/output
- RSSI with 70 dB dynamic range from noise floor
- 4-wire SPI-compatible interface
- Data whitening and automatic CRC generation
- Incoming sync word recognition
- 64-byte transmit/receive FIFO with preload in Stand-by mode
- Supports Manchester encoding/decoding
- Operating voltage 2.1 – 3.6 V
- Supports MiWi™ and MiWi P2P protocols

MRF89XAM8A

- Module with integrated antenna

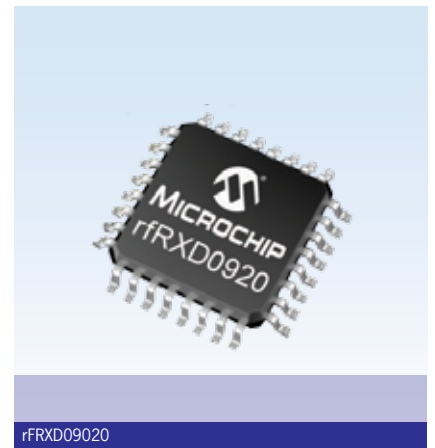
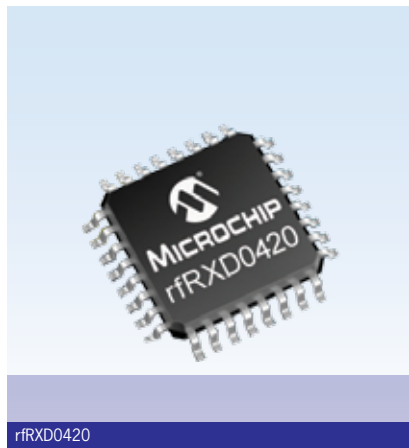

ISM/SRD



rfPIC12F675

The rfPIC12F675 devices pack Microchip's powerful yet easy to program PICmicro® microcontroller architecture and a RF transmitter into a 20-pin package. In addition, it features a 4 channel 10-bit Analog-to-Digital (A/D) converter, one Comparator channel, 128 bytes of EEPROM memory.

- programmable pull-up resistors
- 4 oscillator selections including 4 MHz RC oscillator with programmable calibration and Power-on Reset
- Up to 10 dBm transmit output power
- Up to 40 kbps data rate

rfRXD0420/0920

The rfRXD0420/0920 are low cost, compact single frequency short-range radio receivers requiring only a minimum number of external components for a complete receiver system. The rfRXD0420 covers the receive frequency range of 300 MHz to 450 MHz and the rfRXD0920 covers 800 MHz to 930 MHz. The rfRXD0420 and rfRXD0920 share a common architecture. They can be configured for Amplitude Shift Keying (ASK), Frequency Shift Keying (FSK), or FM modulation. The rfRXD0420/0920 are compatible with rfPIC™ series of RF transmitters.

- Easy interface to PICmicro® microcontroller (MCU) and KEELOQ® decoders
- Low current consumption:
 - <100 µA standby current
 - Active with LNA in high gain mode:
 - 8.2 mA (rfRXD0420)
 - 9.2 mA (rfRXD0920)

RF Transceivers	Modulation	Data rate (kbps)	Freq. range (MHz)	Sensitivity (dBm)	Tx power (dBm)
MRF89XA	FSK /OOK	200	868/915/955	-113	+12.5
MRF49XA	FSK /FHSS	256	434/868/915	-110	+7
Microcontrollers +Transmitter	Program Memory	Program Memory (Kbytes)	EEPROM (Bytes)	RAM (Bytes)	Frequency range (MHz)
rfPIC12F675K	Flash	1792	128	64	290-350
rfPIC12F675F	Flash	1792	128	64	380-450
rfPIC12F675H	Flash	1792	128	64	850-930
RF Receivers	Modulation	Data rate (kbps)	Freq. range (MHz)	Sensitivity (dBm)	
rfRXD0420	ASK, FSK, FM	80	300-450	-111	
rfRXD0920	ASK, FSK, FM	80	300-450	-111	

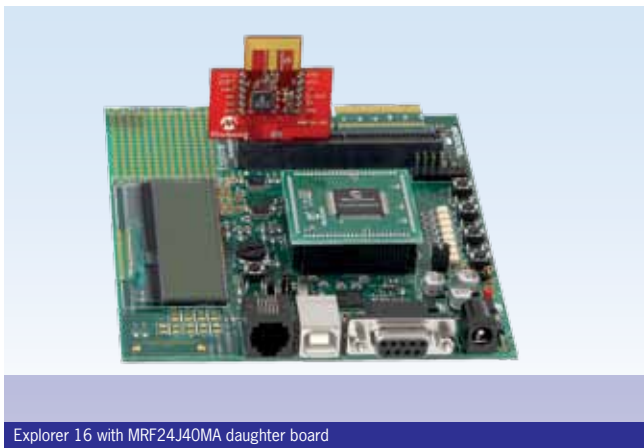

Explorer 16 with MRF24J40MA daughter board



MRF24J40MB daughter board

ISM/SRD



Development and Evaluation

rfPIC Development Kit 1

The rfPIC Development Kit 1 provides design engineers with an easy way to evaluate unidirectional remote sense and control wireless links based on the rfPIC12F675 and rfRXD0420/0920 devices. The kit is based on the popular PICKit™ 1 FLASH Starter Kit and consists of modular building blocks for different transmitters and receivers that can be utilized for prototype systems or to evaluate different options using Microchip products.

Package Contents:

- PICKit™ 1 FLASH starter kit
- 433.92 MHz transmitter
- 315 MHz transmitter
- 433.92 MHz receiver
- 315 MHz receiver
- fPIC software and complete documentation (on CD)

MiWi™ Development Environment

MiWi™ Development Environment is Microchip's proprietary wireless solution which helps customers develop wireless applications and reduce the time to market. The MiWi™ Development Environment (MiWi DE) package includes support for Microchip's proprietary protocols - MiWi™ Mesh and MiWi P2P. These protocols support short-range wireless networking applications. For more detailed information on these protocols, please check the respective application notes. The MiWi Development Environment is optimized for low-power, low data rate, cost sensitive application. It also offers a smaller foot-print relative to the open standard based ZigBee® compliant protocol stack.

MiWi™ Development Environment mainly consists of two interface layers:

- **MiApp** - Using the MiApp interface layer, the application developer can easily switch between different Microchip proprietary wireless protocols such as MiWi Mesh and MiWi P2P without having to change the application firmware.
- **MiMAC** - Using MiMAC layer, the developer can easily switch between different RF transceivers such as MRF24J40 and MRF89XA.

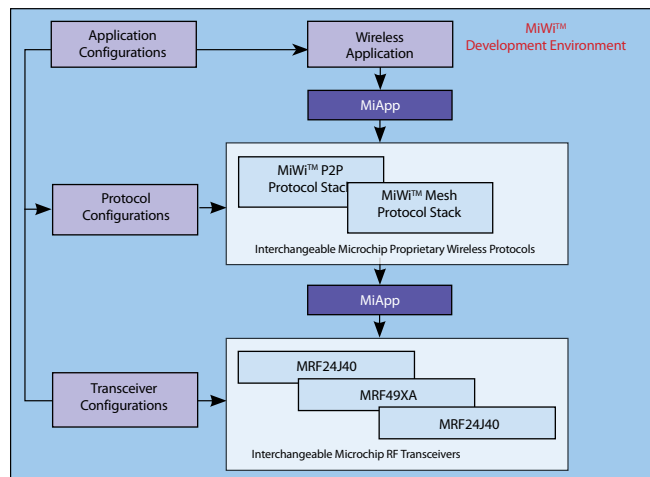

The main advantages of MiWi Development Environment are the ease in developing wireless applications and also ease in portability of the applications across different Microchip RF transceivers and different wireless protocols depending on the application requirements, without having to change the application firmware.



Terminals



PowerOne



TinyOne Lite, Plus, Pro and 2400MC

ISM/SRD



TinyOne™ family

TinyOne™ family consisting of TinyOne™ Lite, TinyOne™ Plus, TinyOne™ Pro, TinyOne™ 2400MC, is a complete line of products for easy integration.

The family offers pin-to-pin compatibility and surface mount device (SMD) half moon technology that is dedicated to wireless applications operating in the ISM bands. The modules (except ZE modules) are delivered with proprietary standard firmware (S-One stack) and proprietary mesh firmware (M-One stack).

The stack is fully configurable and upgradeable over-the-air from a point-to-point communication to a star configuration with listen before talk and allows also mesh networking managed by proprietary mesh firmware (M-One stack).

ME50-868

Telit ME50-868 modules are the latest generation of Wireless M-Bus products compliant with EN13757 part 4 and part 5 Wireless M-Bus standard optimized for one- or two-way data exchange with gas, water, heat and electricity meters and concentrators.

- EN13757-supported S,T, R modes and wake-up on radio
- EN13757-5:2008 mode R and Q
- NTA8130 & DSMR compliant
- OMS compliant
- Channels:
 - 12 (1 radio link A, 1 radio link B, 10 radio link C)
- Stand-by consumption:
 - external wake-up (interrupt) 1 μ A
 - cyclic wake up (internal timer) 3 μ A
- Output power: Up to 14 dBm

New NE, ME and LE Families

New families, of high performing LGA products working in <1GHz and 2.4GHz ISM band will be launched by the end of 2010:

- ME Family, for Wireless M-bus products (first to be launched in Q4 2010 is ME50-868, the smallest in the wireless M-Bus market with lowest consumption in receive mode)
- NE Family for advanced proprietary mesh network (first to be launched Q4 2010 NE50-868 with adjustable output power from 5mW up to 25mW and highly efficient power management on both end nodes and routers that can build a network of up to 10 000 devices)
- LE Family for point-to-point, multipoint, broadcast networks and linear networks e.g. lighting system (first to be launched in Q4 2010 is LE50-868 with the best budget link on the market of 125dB, to be followed in Q1 2011 by LE61-2.4 for application on 2.4GHz)

All the products of ME, LE and NE families (including new products at higher power output foreseen for 2011) will have the 26 x 15mm form factor, the same as the existing ZE Family.



ISM/SRD



ISM band modules and terminals

Type	Form Factor	Range [m]	Frequency [MHz]	RadioData [Kbps]	Output Power [mW]	Embedded Stack Option
TinyOne™						
TinyOne™ Lite 433 MHz RF modules	Embedded	1000	433	9.6, 38.4, 100	up to 10	M-One & S-One
TinyOne™ Lite 868 RF modules	Embedded	500	868	9.6 or 38.4	up to 10	M-One & S-One
TinyOne™ Plus 868 RF modules	Embedded	1500	868	4.8 to 38.4	5, 10 or 25	M-One & S-One
TinyOne™ Plus 868 MHz	Terminal	1500	868	4.8 to 38.4	5, 10 or 25	M-One & S-One
TinyOne™ Pro 868 RF modules	Embedded	4000	868	4.8 to 38.4	500	M-One & S-One
TinyOne™ Pro 868	Terminal	4000	868	4.8 to 38.4	500	M-One & S-One
TinyOne™ Plus 915 MHz RF modules	Embedded	1500	915	38.4	25	S-One
TinyOne™ Pro 915 MHz RF modules	Embedded	4000	915	38.4	500	S-One
PowerOne™						
PowerOne™ 868 MHz RF modules	Compact	16000	868	4.8 and 9.6	25 to 500	S-One
PowerOne™ 868 MHz	Terminal	16000	868	4.8 and 9.6	25 to 500	S-One
IEEE 802.15.4						
TinyOne™ 2400 MC RF modules	Embedded	70	2400	250	1	S-One
IEEE 802.15.4 - ZigBee®						
ZE50-2.4 RF modules	Embedded	200	2400	250	1	Z-One
ZE60-2.4 RF modules	Embedded	1500	2400	250	100	Z-One 2007
ZE51-2.4 modules	Embedded	1000	2400	250	2.5	Z-One PRO
ZE61-2.4 RF modules	Embedded	4000	2400	250	100	Z-One PRO
Wireless M-Bus EN13757						
ME50 - 868	Embedded	2000	868	4.8 - 100	25	M-Bus

433 MHz band

- Frequency: 433.05 – 434.79 MHz
- Standard: ETSI 300-220
- Power: 10 mW
- Duty cycle: 10% to 100%
- Family: TinyOne™ Lite

868 MHz band

- Frequency: 868.00 – 870.00 MHz
- Standard: ETSI 300-220
- Power: 5 to 500 mW
- Duty cycle: 0.1 to 100%
- Families: TinyOne™ Lite/Plus/Pro

2.4 GHz band

- Frequency: 2400 – 2483.5 MHz
- Standard: IEEE 802.15.4
- Power: 1 to 100 mW
- Duty cycle: N/A
- Families: TinyOne™ 2400MC, ZE50/51 - 2.4, ZE60/61 - 2.4

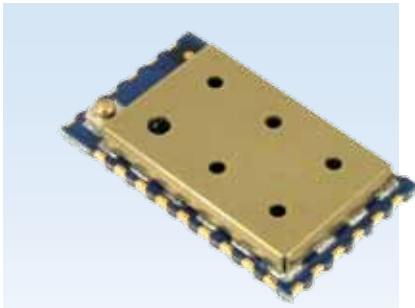

ZWIR4512



ISM/SRD



ZWIR4512-I

IPv6 Module (6LoWPAN)

The ZWIR4512-I Radio Module enables secure wireless low-power IPv6 communication for sensors and small devices. It utilizes 6LoWPAN, the first Internet Engineering Task Force (IETF) standard to build wireless, low-power IP-based sensor and device networks.

- Transceiver: ZMDI – ZWIR4502
- MCU: STM32 – ARM Cortex M3
- RF parameters:
 - 10 channels in US Mode (906 – 924 MHz)
 - 4 channels in EU Mode (865.3 – 868.3 MHz)
 - Output power: up to 10 dBm
 - 20 / 100 kbps data rate in EU Mode
 - 40 / 250 kbps data rate in US Mode
 - Range: up to 1.5 km
- Supply voltage: 2V – 3.6V
- Current consumption
 - Deep sleep: 3 μ A
 - Sleep: <1 mA
 - Transmit: 24 mA @ 0dBm
 - Receive: 19 mA
- Interfaces
 - 2xUART, SPI, USB, 2xADC, 2xDAC, 2xPWM, CAN, JTAG
- Memory for user application
 - 192 kB flash
 - 16 – 24 kB RAM
- Antenna connection
 - On-board UFL connector
 - Module pin for external antenna
- Size 17 x 28 mm
- Surface mountable

Firmware Package

ZMDI provides a royalty-free firmware package usable with ZWIR4512-I radio modules.

- Serial Command Interface for straightforward secure communication
- 6LoWPAN library
 - C-API for full access to all communication functions
 - Full access to microcontroller peripherals
- Security libraries
 - IPsec standard-compliant encryption and authentication
 - IKEv2 standard-compliant cryptographic key management
- Over-the-air (OTA) update library
 - Completely configurable OTA implementation
 - Host software package for OTA distribution

ZWIR4512-I Development Kit

The ZWIR4512-I Development Kit allows easy evaluation of communication functionality and enables rapid prototyping of application hardware requiring external circuitry. All module I/Os are accessible over 2.54 mm perfboard-compatible pin-headers. The kit includes firmware, allowing transparent integration of WPAN modules into Ethernet-based network infrastructures independent from the application.

- Three Development Boards
- On-board ZWIR4512 radio module
- On-board JTAG adapter
- Ethernet receptacle
- UART-accessible via virtual COM port over USB
- 2.54 mm perfboard-compatible headers with access to all I/Os
- Firmware for transparent integration of WPAN into Ethernet
- Dimensions 108 mm x 80 mm x 26 mm
- Supply voltage 3.5 V – 6 V



ZigBee™



MRF24J40 2.4 GHz transceiver

- IEEE 802.15.4 standard
- Supports ZigBee™, MiWi™, MiWi™ P2P and proprietary wireless network protocols
- Simple four-wire SPI interface 0dBm typical output power
- Low current consumption: RX mode: 19 mA
TX mode: 23 mA, Sleep: 2µA
- Hardware CSMA-CA mechanism
- Automatic ACK response
- Hardware security engine (AES-128)
- Automatic packet retransmit capable
- Small 40-pin leadless QFN 6 x 6 mm² package

- ZigBee™ Coordinator (Controller)
- ZigBee™ Full Function Device (Router)
- ZigBee™ Reduced Function Device (End Device)

MRF24J40MA/MB transceiver module

- Based on MRF24J40
- Supports ZigBee™, MiWi™, MiWi™ P2P and proprietary wireless network protocols
- Small size:
17.8 x 27.9 mm (MA), 22.9 x 33.0 mm (MB)
- Surface mountable
- Integrated crystal, internal voltage regulator, matching circuitry and PCB antenna
- MB also have low Noise Amplifier (LNA) and Power Amplifier (PA)
- Output power: 0dBm (MA), +20 dBm (MB)
- Radio regulation certification for United States (FCC), Canada (IC) and Europe (ETSI)
- Compatible with Microchip microcontroller families: PIC16F, PIC18F, PIC24F/H, dsPIC33 and PIC32
- Temperature range: -40°C to +85°C
- Simple, four-wire SPI interface
- Low-current consumption:
 - RX mode: 19/25 mA, MA/MB
 - TX mode: 23/130 mA, MA/MB
- Operating voltage: 2.4 – 3.6 V

MiWi™ information on page 28

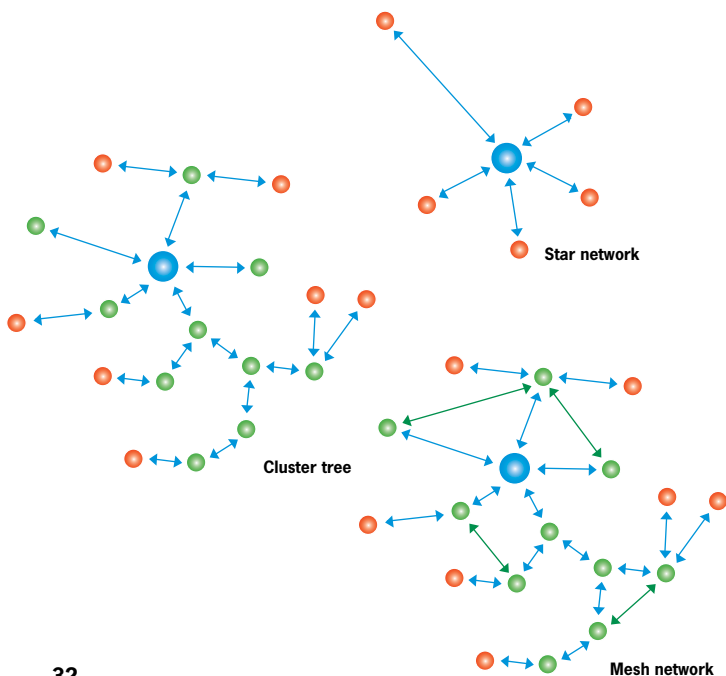

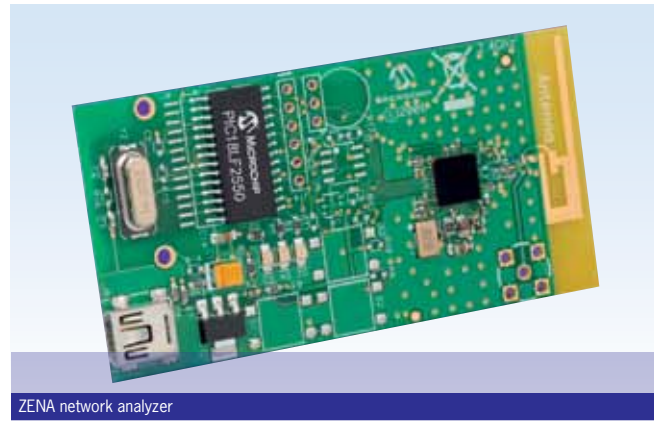

ZigBee™



ZigBee™ offerings from Microchip

Microchip's ZigBee™ Compliant Platforms consist of the 2.4 GHz IEEE 802.15.4 compliant MRF24J40/MA/MB transceiver products, the PIC18, PIC24, dsPIC, and PIC32 families of microcontrollers, and the certified firmware protocol stacks.

- Royalty-free ZigBee™ protocol stack
- Efficient footprint for entire ZigBee™ protocol
- Source-code format, allowing designers to customize their products
- Utilize Microchip's broad portfolio of compatible PIC® microcontrollers

Software solutions

ZigBee™ Smart Energy Profile (SEP) Suite

SEP Suite includes:

- ZigBee™ Smart Energy Profile Application
- Certified ZigBee™ PRO Stack
- ZigBee™ Cluster Library (ZCL)

ZigBee™ PRO

- Microchip's Certified ZigBee™ PRO Compliant Platform (ZCP)
- Certified ZigBee™ PRO Stack
- PIC24, dsPIC or PIC32 family of Microcontrollers
- MRF24J40, MRF24J40MA, MRF24J40MB 2.4GHz IEEE 802.15.4 transceiver/modules
- Full Featured, Interoperable, Mesh and Star Network topologies

ZigBee™ RF4CE

- Microchip's Certified ZigBee™ RF4CE Compliant Platform
- Certified ZigBee™ RF4CE Stack
- PIC® family of Microcontrollers
- MRF24J40, MRF24J40MA, MRF24J40MB 2.4GHz IEEE 802.15.4 transceiver/modules
- Standards based peer-to-peer protocol stack for RF for Consumer Electronics

ZigBee™ 2006

- Microchip's Certified ZigBee™ 2006 Compliant Platform (ZCP)
- Certified ZigBee™ 2006 Stack
- PIC18, PIC24 or dsPIC family of Microcontrollers
- MRF24J40, MRF24J40MA, MRF24J40MB 2.4GHz IEEE 802.15.4 transceiver/modules
- Full Featured, Interoperable, Mesh and Star Network topologies

MiWi™

Microchip also supports a free MiWi™ protocol stack for IEEE 802.15.4 wireless networking ideal for cost-sensitive applications with limited memory. MiWi™ protocol is a free, small footprint protocol developed by Microchip for customers who do not require ZigBee™ protocol interoperability, but want to use IEEE 802.15.4 transceivers in simple low-cost peer-to-peer, star and mesh networks. No certification is required and the protocol stack is provided under a free license when using Microchip microcontrollers.

More information on page 28



ZigBee™



Renesas Electronics offers a fully integrated hardware and software platform for a wide range of low-data-rate wireless applications. The Renesas ZigBee System Solution provides a comprehensive platform for product developers. It comes complete with microcontroller, radio, ZigBee software stack, MAC software, and integrated development environment.

The Renesas ZigBee System Solution includes:

Low-Power, High-Performance M16C Microcontrollers

- Common architecture addresses the entire 8-bit through 32-bit price/performance application space
- Multi-year battery performance lowers operating costs
- Extensive RAM/ROM/Flash memory and peripheral combinations allow flexibility in application design
- Best pin-to-pin and code-compatible platform minimizes re-engineering costs and development times for product variants and upgrades.

Standards-Based Radios

- Full spectrum coverage with transceivers in 2.4GHz
- Reference design with true ZigBee Stack and IEEE802.15.4 MAC software is fully tested and available from Renesas.

MAC Software

- Complete IEEE 802.15.4 implementation has passed IEEE802.15.4 level 1 and level 2 certification.
- Renesas has a complete lite-weight MAC for non-ZigBee 802.15.4 applications.

ZigBee/IEEE 802.15.4 Software Stack

- Renesas ZigBee Software stack (v1.0 release 6) and IEEE802.15.4 MAC has passed ZigBee Compliant Platform certification (ZCP) for M16C/6B, 78K0R and V850 Microcontrollers.

ZigBee Product Development Kits

The 78K0R ZigBee Professional Premium development platform enables rapid ZigBee application development. Supporting the HA profile and optional SE profile.

The V850 ZigBee professional premium gateway developers kit enables the development of advanced ZigBee to Ethernet gateway solutions.

M16C/6B

The M16C/6B microcomputers (MCUs) incorporate the M16C/60 Series CPU core and flash memory. These MCUs also function as low-power-consumption transceivers in the 2.4 GHz band.

- RF
 - RF frequency: 2405 MHz to 2480 MHz
 - 16 RF channels (channel 11-26)
 - Reception sensitivity: 94 dBm
 - Transmission output level: 0 dBm
- Baseband
 - 127-byte transmit RAM, 127-byte receive RAM × 2
 - Address filter
 - Automatic ACK response function
- CRC Calculator
- Watchdog Timer
- Supply voltage: 2.2 – 3.6 V
- AES Encryption / Decryption: Key length 128 bits
- Memory: Program Flash:
 - 256kB (64 pin version)
 - 192kB (48 pin version)
- 20 kB RAM
- 4kB x 2 Data Flash



ZigBee™



SPZB250 ZigBee® module

SPZB250 is a low power consumption ZigBee® module based on EM250 ZigBee® system-on-chip, which integrates a 16 bit processor together with a 2.4 GHz, IEEE 802.15.4-compliant transceiver as well as IEEE 802.15.4 PHY and MAC. It enables OEMs to easily add wireless networking capability to any electronic device.

- Integrated 2.4 GHz, IEEE 802.15.4-compliant transceiver, PHY and MAC
- +3 dBm nominal TX output power
- +5 dBm in boost mode
- -95 dBm (typ) RX sensitivity
- 128 kb embedded Flash and 5 kb integrated
- SRAM for program and data storage
- 17 GPIO with alternate functions: GPIOs, UART, I2C, SPI, ADC
- ADC, sigma-delta converter with 12-bit resolution
- On board 24 MHz stable crystal
- Watchdog timer and power on reset
- Single supply voltage 2.1 to 3.6 Vdc
- CE and FCC compliance.

SPZB260-PRO ZigBee® module

SPZB260-PRO is a low power consumption ZigBee® module optimized for embedded applications. It enables OEMs to easily add wireless capability to electronic devices. The module is based on SN260 ZigBee® network processor, which integrates a 2.4 GHz, IEEE 802.15.4-compliant transceiver as well as IEEE 802.15.4 PHY and MAC. The module is controlled by means of a standard serial interface (SPI) allowing the connections to a variety of host microcontrollers.

- Integrated 2.4 GHz, IEEE 802.15.4-compliant transceiver:
 - +3 dBm nominal TX output power
 - +5 dBm in boost mode
 - -95 dBm RX sensitivity
- RX filtering for co-existence with IEEE 802.11g, and Bluetooth devices
- Controlled by a standard serial line for an easy interface of host microcontrollers (SPI)
- Embedded flash and integrated RAM for program and data storage
- On board 24 MHz stable crystal
- Watchdog timer and power-on reset
- Single supply voltage 2.1 to 3.6 Vdc
- CE and FCC compliance.
- Shipped with version 3.3.1 of EmberZNet PRO

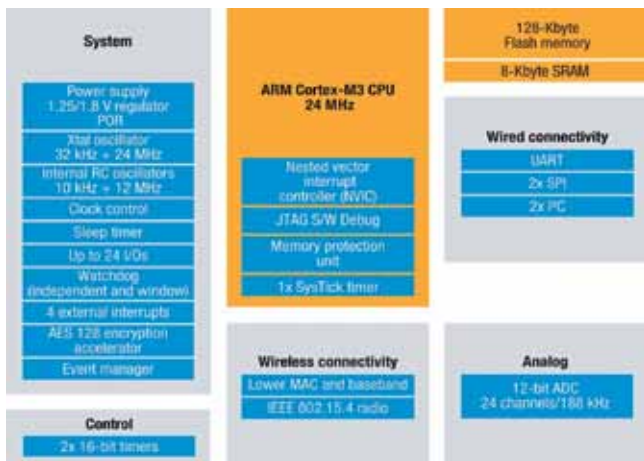

ZigBee™



STM32W108 High-performance, IEEE 802.15.4 wireless system-on-chip

The STM32 family is expanding to the wireless network domain bringing outstanding radio and low-power micro-controller performances. With a configurable total link budget up to 109 dB and the efficiency of the ARM Cortex-M3 core, the STM32W is a perfect fit for the wireless sensor network market. Compliant with the IEEE 802.15.4 radio standard, this open and flexible platform supports the most popular protocol stacks such as RF4CE, ZigBee-PRO, 6LoWPAN and more.

- Complete system-on-chip
 - 32-bit ARM® Cortex™-M3 processor
 - 128-Kbyte Flash, 8-Kbyte RAM memory
 - AES128 encryption accelerator
 - Flexible ADC, SPI/UART/TWI serial communications, and general-purpose timers
 - 24 highly configurable GPIOs with Schmitt trigger inputs
- Low power consumption, advanced management
 - Low-frequency internal RC oscillator for low-power sleep timing
 - High-frequency internal RC oscillator for fast (100 μs) processor start-up from sleep
- Single voltage operation: 2.1-3.6 V
- Support for external power amplifier
- Small 7x7 mm 48-pin VFQFPN package or 6x6 mm 40-pin VFQFPN package

Applications

- Smart energy
- Building automation and control
- Home automation and control
- Security and monitoring
- ZigBee® Pro wireless sensor networking
- RF4CE products and remote controls
- 6LoWPAN and custom protocols

Development tools

As for all STM32 products, a complete development tool offer is available.

STM32W108B-SK: application board + Primer2 + network analyzer and IAR compiler

STM32W108B-KEXT: set of 4 additional application boards to build a mesh network

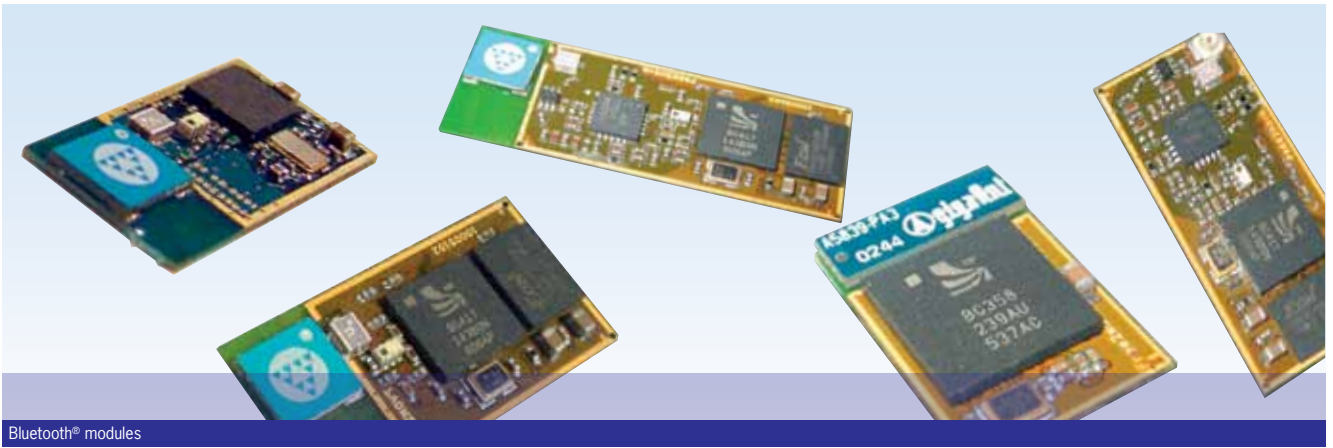

Bluetooth® modules

Bluetooth®

FREE2MOVE

Bluetooth® modules

Module	Bluetooth® Spec.	Class (1)	Max. output power	Avg. power cons. (2)	Antenna	Codec	Range (3)	CE, FCC	Size (LxW)
F2M03GX	2.0 + EDR	1 / 2 / 3	+18dBm	14mA	NO	NO	1500m	YES	33 x 15
F2M03GXA	2.0 + EDR	1 / 2 / 3	+18dBm	14mA	YES	NO	1000m	YES	40 x 15
F2M03GLA	2.0 + EDR	1 / 2 / 3	+8dBm	13mA	YES	NO	250m	YES	28 x 15
F2M03MLA	2.0	1 / 2 / 3	+8dBm	21mA*	YES	YES / Stereo	150m	YES	18 x 13
F2M03ALA	2.1 + EDR	2 / 3	+4dBm	14mA	YES	YES / Mono	100m	YES	24 x 13

* The F2M03MLA is measured at the slave with a SCO-connection, HV3, 30ms sniff mode.

(1) The module is qualified as the class presented first, but it is possible to restrict the output power to comply with a class2 or class3 device.

(2) Power consumption measured at the master module when sending data at 115200baud between two modules and the Wireless UART firmware at a distance of 5m, sniff mode enabled (125ms).

(3) Approximate range in line of sight.

Bluetooth® 2.1+EDR Audio low power module with antenna (F2M03ALA)

- Fully qualified end product with Bluetooth v2.1+EDR, CE and FCC
- Industrial temperature range -40°C to +85°C
- Serial interface up to 3 Mbps
- Extensive digital and analog I/O interface
- 15-bit mono audio codec
- Analog and digital audio interface
- Low power modes
- Fully footprint compatible with the discontinued F2M03AC2



The standard firmware for F2M03ALA is the exceedingly reliable and powerful easy-to-use Wireless UART v4 firmware implementing the Bluetooth Serial Port Profile (SPP).



Bluetooth®

FREE2MOVE

Bluetooth® 2.0 + EDR extended range modules (F2M03GX/GXA)

- Fully qualified end product with Bluetooth v2.0+EDR, CE and FCC
- Industrial temperature range: -40°C to +85°C
- USB v2.0 compliant
- Serial interface up to 4Mbps
- Extensive digital and analog I/O interface
- PCM interface for up to 3 simultaneous voice channels
- Large external memory for custom applications
- Supports many Bluetooth profiles
- Support for 802.11b/g Co-Existence
- Available with complete Bluetooth software stack
- Wireless UART functionality without extra protocol

F2M03GX/GXA has, by default, the exceedingly reliable and powerful easy-to-use Wireless UART firmware implementing the Bluetooth Serial Port Profile (SPP). All information sent to the serial interface is transmitted transparently via Bluetooth to the connected remote device. F2M03GX/GXA are also available with a HCI firmware. Customized solutions with the additional profiles HSP, HFP, DUN, OPP or HID can be delivered.

Accessories for F2M03GX

Type	Order number	Part number	Description
Adapter cable	WIREAC1037	ADAPTER-IPX-SMA/F (BH) 10cm	Adapter cable IPX (U.FL) to SMA/f BH 10cm
Adapter cable	WIREAC1112	ADAPTER-IPX-SMA/F (BH) 15cm	Adapter cable IPX (U.FL) to SMA/f BH 15cm
Adapter cable	WIREAC1055	ADAPTER-IPX-SMA/F (BH) 20cm	Adapter cable IPX (U.FL) to SMA/f BH 20cm
Adapter cable	WIREAC1077	ADAPTER-IPX-SMA/M(BH) 10cm	Adapter cable IPX (U.FL) to SMA/M 10cm
Adapter cable	WIREAC1101	ADAPTER-U.FL-85MM+SMA-F PCB	Adapter cable IPX (U.FL) to SMA/f PCB 85mm
Adapter cable	WIREAC1127	ADAPTER-IPX-OPEN-20CM	Adapter cable IPX (U.FL) to 20cm open end
Antenna / Bluetooth	WIREAC1131	PF-14E	Stub antenna 2,4GHz SMA/m
Antenna / Bluetooth	WIREAC1076	WA-01	Swivel ant. 2,4GHz SMA/m
Antenna / Bluetooth	COREC22707	CAN4311111002451K	Surfaced mounted, 2,45GHz

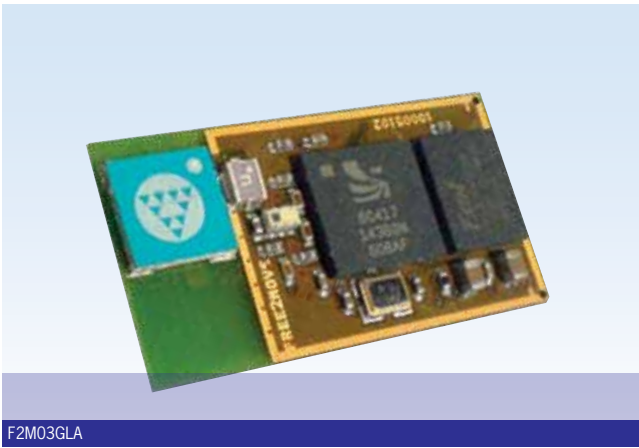

Bluetooth®

FREE2MOVE

Free2move Bluetooth® Module – F2M03GLA

- Fully qualified end product with Bluetooth v2.0+EDR, CE and FCC
- Industrial temperature: range -40°C to +85°C
- USB v2.0 compliant
- Serial interface up to 4Mbps
- Extensive digital and analog I/O interface
- PCM interface for up to 3 simultaneous voice channels
- Large external memory for custom applications
- Support for 802.11b/g co-existence
- Available with complete Bluetooth software stack
- Wireless UART functionality without extra protocol

F2M03GLA can be delivered with the exceedingly reliable and powerful easy-to-use Wireless UART firmware implementing the Bluetooth Serial Port Profile (SPP). All information sent to the serial interface is transmitted transparently via Bluetooth to the connected remote device. F2M03GLA is also available with a HCI firmware. Customized solutions with the additional profiles HSP, HFP, DUN, OPP or HID can be delivered.

Bluetooths 2.0 low power multimedia module – F2M03MLA

- Fully qualified end product with Bluetooth v2.0, CE and FCC
- Industrial temperature: range -40°C to +85°C
- Serial interface up to 1.5Mbps
- Extensive digital and analog I/O interface
- 16-bit stereo codec
- 32-bit Kalimba DSP for enhanced audio applications and other general-purpose applications
- Many digital audio options: PCM, I2S and SPDIF
- Large external memory for custom applications

The standard Wireless Audio firmware is intended for most Bluetooth audio applications. Three Bluetooth profiles are currently supported: Headset, HandsFree and A2DP. Customized firmware solutions with additional profiles such as HCI, SPP, DUN, OPP and HID can be delivered. It is also possible to implement advanced audio processing algorithms to greatly improve the sound quality.



F2M01SXA

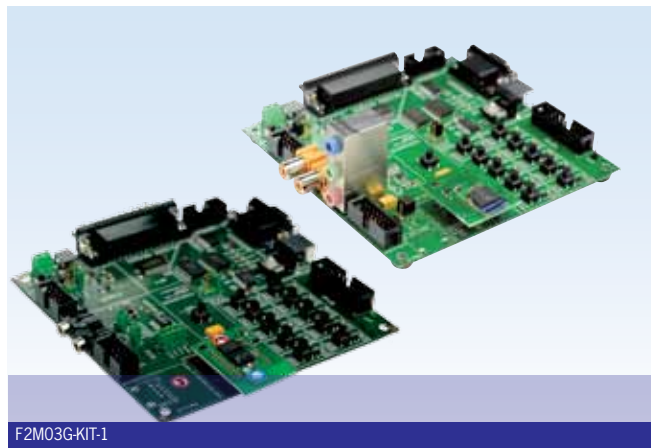

F2M03G-KIT-1

Bluetooth®

FREE2MOVE

Uncord™

Free2move Serial Port Plug – F2M01SXA

- Provides transparent RS-232 serial cable replacement
- No need for external drivers
- Power is supplied via D-SUB connector or mini-USB connector
- Implements the Bluetooth Serial Port Profile and Generic Access Profile
- Interoperability with PDA, laptops, etc.
- Range up to 500 m (line of sight)
- Configurable for use of different baud rates and serial settings
- Easy-to-use Windows configuration tool available
- Small form factor 37x18x60 mm
- Supply voltage 5-30 VDC
- Led indicators for power, data and status monitoring

Uncord™ plug can be applied to almost every application that currently uses cables for serial communication.

If throughput and latency requirements are met, it is easy to connect the plug to the serial interface. The Ad Hoc connectivity will give you the serial link as soon as the communicating devices are within range of each other. Uncord™ supports the serial port profile and is interoperable with PDAs, laptops and other Bluetooth devices supporting this profile. A user-friendly Windows application is included that can be used to configure the plug to suit your requirements. The software you have developed for your serial ports can remain unchanged when using the paired serial cable plugs.

Evaluation/development kits

Evaluation kit for general purpose modules – F2M03G-KIT-1

F2M03G-KIT is the evaluation kit for Free2move's general-purpose Bluetooth modules. The evaluation board has extensive I/O functionality for both data and audio streams. The evaluation board is primarily made to evaluate the Wireless UART firmware, but is also intended to be used for other firmwares and custom made applications. The evaluation board gives the possibility to upgrade the Bluetooth module with new firmware using Free2move's Flash utility.

Evaluation kit for multimedia and audio modules – F2M03M-KIT-1

F2M03M-KIT is the evaluation kit for Free2move's multimedia Bluetooth modules. The evaluation board has extensive I/O functionality for both data and stereo audio streams. The evaluation board is primarily made to evaluate the Wireless Audio firmwares, but is also intended to be used for other firmwares and custom-made applications. The evaluation board gives the possibility to upgrade the Bluetooth module with new firmware using Free2move's Flash utility.

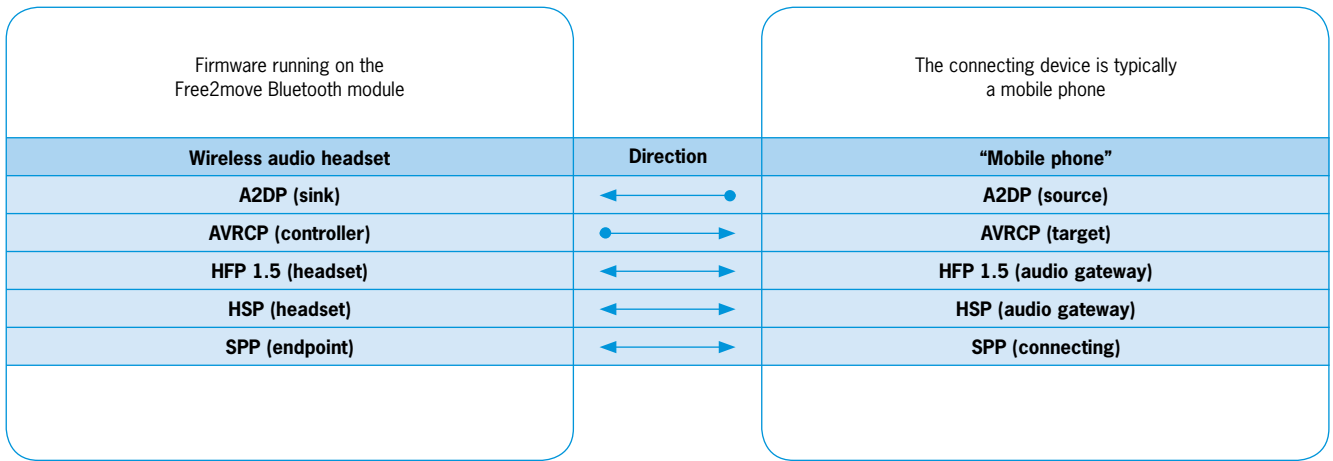

Wireless Audio Headset

Standard software products



Wireless UART

Free2move's Wireless UART (WU) firmware is intended to replace the cable(s) connecting portable and/or fixed electronic devices. Key features are robustness, high configurability, high security, low complexity and low power.

The WU firmware is compliant with the Bluetooth Serial Port Profile (SPP) for setting up emulated serial cable connections between connected devices. There is no additional need for drivers or an external host with Bluetooth software when using the WU firmware.

The WU application runs on top of an embedded Bluetooth v2.0 + EDR compliant stack, including protocols up to the RFCOMM layer. Point-to-point connections are supported. This means that a unit running WU can be either a master of one slave unit or participate in a piconet as a slave. Up to 7 slaves can be active in a piconet.

The WU firmware offers one asynchronous data channel and one synchronous voice channel, both channels capable of full duplex transmissions.

When a successful Bluetooth connection is established, the data channel and the voice channel can be used simultaneously or separately. All information sent/received at the data/voice interface of the WU unit is exchanged transparently via Bluetooth with the connected remote device.

The WU unit is set to operate in a default mode that allows the user to communicate via the asynchronous data channel over Bluetooth, as soon as a connection has been established. This can be achieved without sending any configuration commands to the WU firmware. However, as long as no Bluetooth connection is established, it is possible to configure the WU firmware via commands sent on the data interface.

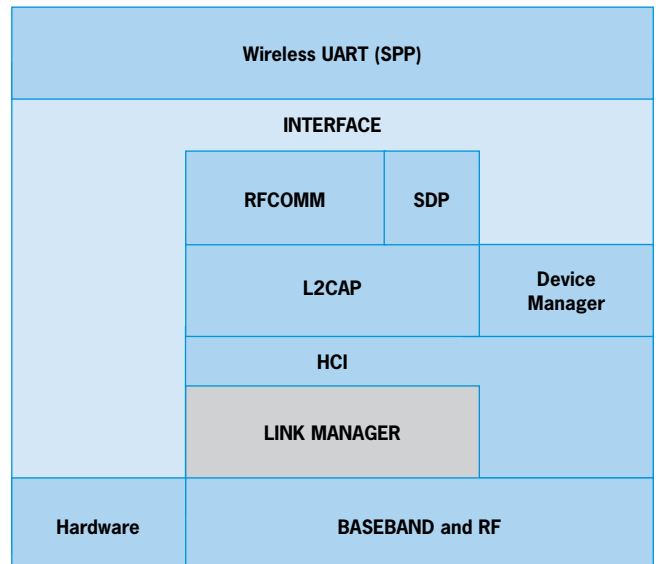

Wireless Audio Headset

Wireless Audio Headset (WAH) is Free2move's standard firmware for Headset applications. It is intended for applications that want to incorporate Headset functionality to be able to communicate with, for example, mobile phones. The firmware can be used either as stand-alone with a button interface as the only input of controlling the firmware or connected to another serial device (e.g. microcontroller) through the UART interface.

The current version includes the following Bluetooth profiles:

- A2DP (sink)
- AVRCP (controller)
- HFP 1.5 (headset)
- HSP (headset)
- SPP (slave)

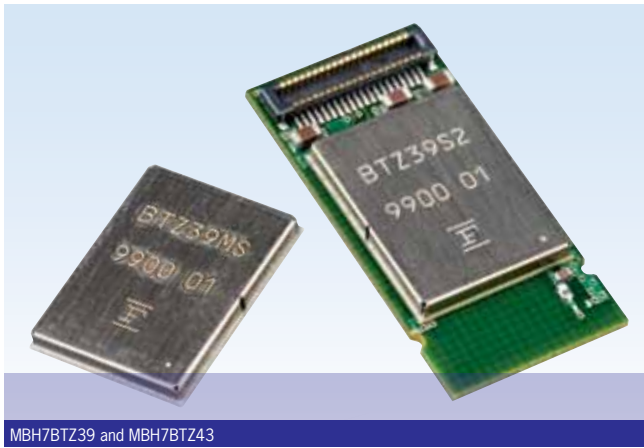

MBH7BTZ39 and MBH7BTZ43

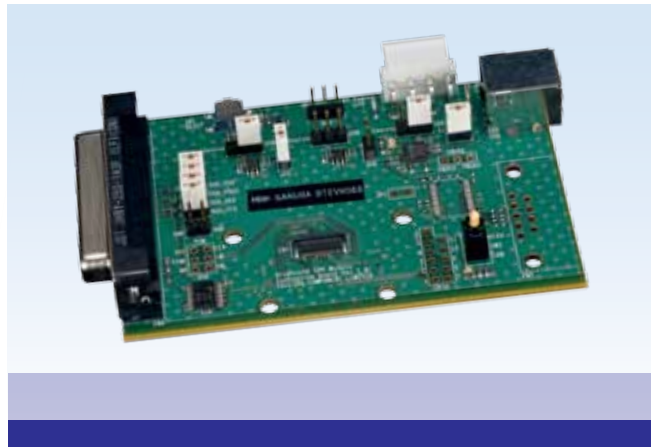

Bluetooth®



Bluetooth SSP module - Power Class 2

MBH7BTZ39

- Bluetooth specification version 2.1 + EDR compliant
- Power Class 2 (+4 dBm max.)
- Upper layer protocol stack (L2CAP, SDP, RFCOMM) and profiles (GAP, SPP) are embedded
- Receiver sensitivity: basic rate -86dBm max.
- Hardware interface: UART (9.6k ~4 Mbps)
- Software interface: simple proprietary command
- Operating temperature: -20 °C to +70 °C
- Supply voltage: 2.7 to 3.6 VDC
- Built-in crystal
- Built-in 8Mbit flash memory
- 12.4 x 9.4 x 1.5 mm
- RoHS compliant
- Surface mount module

MBH7BTZ42

- Same features as MBH7BTZ39 with integrated antenna
- 17.6 x 10.6 x 1.9 mm
- Surface mount module

MBH7BTZ43

- Same features as MBH7BTZ39 with integrated antenna and connector
- 22.5 x 10.6 x 2.3 mm

Bluetooth SSP module - Power Class 1

MBH7BTZ44

- Bluetooth specification version 2.1 + EDR compliant
- Power Class 1 (+20 dBm max.)
- Upper layer protocol stack (L2CAP, SDP, RFCOMM) and profiles (GAP, SPP) are embedded
- Receiver sensitivity: basic rate -82 dBm max.
- Hardware interface: UART (9.6k ~4 Mbps)
- Software interface: simple proprietary command
- Operating temperature: -20 °C to +70 °C
- Supply voltage: 2.7 to 3.6 VDC
- Built-in crystal
- Built-in 8Mbit flash memory
- 12.4 x 10.0 x 1.55 mm
- Surface mount module
- RoHS compliant

MBH7BTZ45

- Same features as MBH7BTZ44 with integrated antenna
- 17.6 x 10.6 x 2.3 mm
- Surface mount module

MBH7BTZ46

- Same features as MBH7BTZ44 with integrated antenna and connector
- 22.5 x 10.6 x 2.3 mm

Evaluation Boards

Evaluation boards are available for the standard product range.

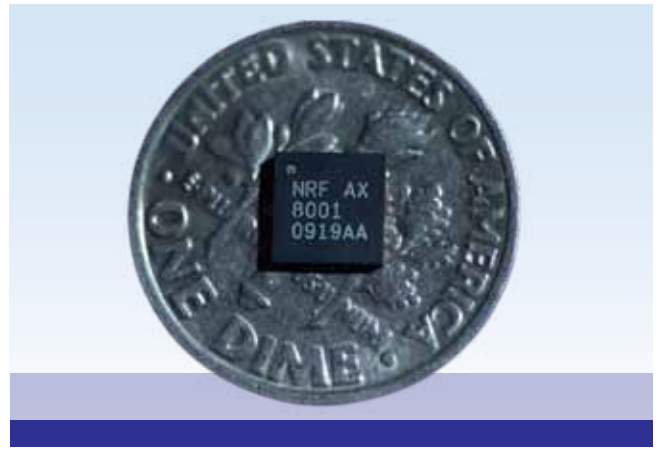

Bluetooth®



Bluetooth® Low Energy

The Bluetooth SIG (Special Interest Group) released version 4.0 of the specification in June 2010. This specification includes the Low Energy version of Bluetooth.

The LE version is for applications that need to take very little power (battery powered) and only need small data transmissions. LE solutions can be of two different versions, single mode or dual mode. Single mode devices only have the LE part of the Bluetooth specification implemented; dual mode devices also have the Basic Rate (BR) part together with the LE part. The μ Blue™ connectivity-on-chip products from Nordic Semiconductor are single mode (slave) low energy solutions.

Micro ampere Bluetooth® wireless technology from Nordic Semiconductor

μ Blue™ is the upcoming single mode Bluetooth low energy technology solution from Nordic Semiconductor. It will be available in a number of variants suited for different applications.

The first products are single mode slave solutions suitable for a range of applications including watches, remote controls, mobile phone peripherals and sports and health-care sensors. The next range of products are single mode master solutions aimed at pure Bluetooth low energy application including sports watches, consumer electronic equipment and sensors hubs.

nRF8001

Single mode Bluetooth low energy slave connectivity-on-chip solution

The nRF8001 is the first member of Nordic Semiconductor's μ Blue family of Bluetooth low energy solutions. It is designed to be used in conjunction with an external microcontroller running the application. The nRF8001 integrates a complete PHY, Link Controller and Host single mode Bluetooth low energy subsystem and features a simple SPI based interface to the application microcontroller.

This system segmentation allows the nRF8001 to be used with the best-fit microcontroller for a specific application as well as ease integration and end product qualification as application and protocol stack does not share the same microcontroller.

- Profiles and example applications provided in μ Blue SDK
- Cost and power optimized for slave operation
- 1.9 – 3.6 V operation
- Sub 14 mA peak current with linear voltage regulator
- Supports sub 10 μ A average current operation
- Ultra low power 32 kHz crystal and RC oscillators
- Support operation without external 32 kHz crystal
- Battery voltage monitor
- Temperature sensor
- RoHS compliant
- 5x5 mm 32-pin QFN package

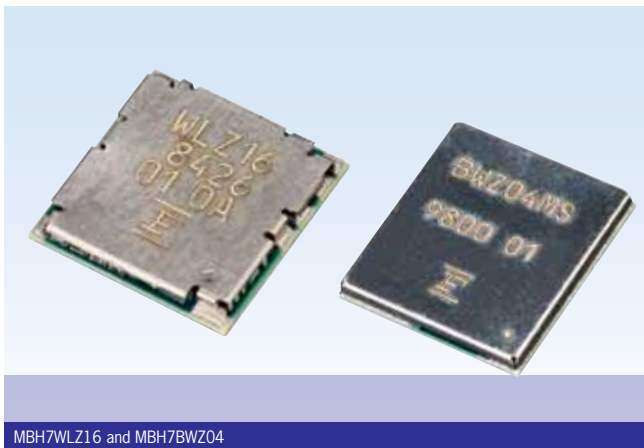

MBH7WLZ16 and MBH7BWZ04



MBH7WLZ22

Wireless LAN



MBH7WLZ16/MBH7WLZ23

Wireless LAN module - 802.11b/g / 802.11a/b/g

- Host interface: SDIO, SPI
- Power supply voltage: 1.8 - 3.0 V
- Operating temperature: -20 to +70 °C
- Security: WEP (64/128 bit), WPA, WPA2
- Antenna: single port (MBH7WLZ16)
- Antenna diversity support (MBH7WLZ23)
- Bluetooth coexistence (2/3/4 wire)
- IEEE802.11e QoS
- Package: LGA 60 pin
- 8.5 x 8.5 x 1.2 mm (MBH7WLZ16)
- RoHS compliant
- 12.0 x 12.0 x 1.8 mm (MBH7WLZ23)

MBH7WLZ21

Wireless LAN module - 802.11 b/g/n, USB

- Host interface: USB 2.0
- Power supply: 3.3 V
- Operating temperature: -10 to +70 °C
- Built-in crystal
- Security: WEP (64/128bit), WPA, WPA2
- Diversity antenna support
- QoS: WMM, WMM-PS
- RoHS compliant

MBH7WLZ22

Wireless LAN module - 802.11 b/g/n, USB

- Host interface: USB 2.0
- Power supply: 5.0 V
- Operating temperature: -10 to +70 °C
- Built-in crystal
- Security: WEP (64/128 bit), WPA, WPA2
- Built-in antenna
- QoS: WMM, WMM-PS
- Package: USB dongle 17.5 x 59 x 4.8 mm
- RoHS compliant

MBH7BWZ04

Wireless LAN and Bluetooth Combo module

- Bluetooth specification version 2.1 + EDR compliant (HCI)/IEEE802.11b/g compliant
- Supply voltage: 3.0 to 4.2 V
- Operating temperature: 2 to +70 °C
- Built-in EEPROM, voltage regulator, oscillator
- Bluetooth + WLAN co-existence with single RF I/O
- Package: LGA 60 pin with centre GND pads (SMT)
- 10.0 x 11.2 x 1.4 mm
- Audio interface: PCM
- RoHS compliant



MRF24WB0MA

Wireless LAN



MRF24WB0MA/B

2.4 GHz, IEEE 802.11 b/g Transceiver Module

MRF24WB0MA/B is certified IEEE 802.11 Wi-Fi radio transceiver modules. The MRF24WB0MA has an integrated PCB antenna, MRF24WB0MB has a U.FL connector for external antenna, matching circuitry, and supports Wi-Fi with the free TCP/IP protocol stack. The MRF24WB0MA/B modules connects to hundreds of PIC® microcontrollers via a 4-wire SPI interface and is an ideal solution for low-power, low data-rate Wi-Fi sensor networks, home automation, building automation and consumer applications.

- Data Rate: 1 and 2 Mbps
- IEEE Std. 802.11b/g compatible
- Small size: 21 x 31 mm 36-pin Surface Mount Module
- Range: up to 400 m
- Designed for use with Microchip microcontroller families with downloadable Microchip TCP/IP stack
- Single operating voltage: 2.7 V - 3.6 V (3.3 V typical)
- Simple, four-wire SPI interface with interrupt
- Low-current consumption:
 - RX mode 85 mA
 - TX mode 154 mA (+10 dBm typical)
 - Sleep 250 μ A
 - Hibernate \leq 0.1 μ A
- Automatic MAC packet retransmit
- Supports 802.1x, 802.1i security: WEP, WPA-PSK and WPA-2-PSK

Microchip Development Tools for Wi-Fi®

Wi-Fi® development is easy with MRF24WB0MA PICtail hardware, an optimized driver with seamless integration into the TCP/IP stack, documentation and demo applications.

The Wi-Fi® PICtail: The PICtail contains MRF24WB0MA Wi-Fi module and interfaces with a Microchip PIC® microcontroller through SPI.

Development Board: Developers have the option to choose between an Explorer 16 or PICDEM.net 2 for Wi-Fi development. The board contains the PIC® microcontroller and provides the SPI interface to interface with MRF24WB0MA Wi-Fi module.

System software: Software is optimized for fast prototyping within Microchip's development environment

Wi-Fi driver is integrated with Microchip TCP/IP networking stack. There's no need to download a separate driver for Wi-Fi® or software development.



SX-SDCAG

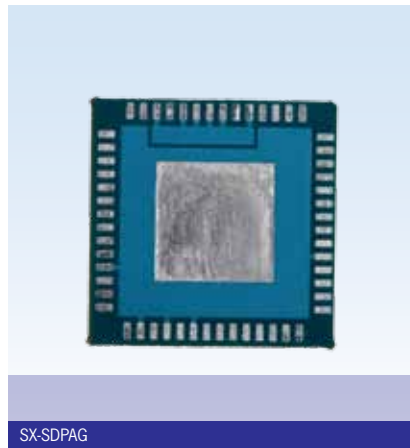

SX-SDPAG



SX-SDPBG

Wireless LAN



SX-SDCAG

SDIO Card Module for 802.11a/b/g

The SX-SDCAG is an 802.11a/b/g Radio/Baseband SDIO Card especially for OEM embedded applications. The module is an ultracompact wireless solution for 802.11a/b/g and it is ideal for low power, battery-operated devices. Diversity antenna compatible.

- Electrical Interface: SDIO V 1.1 (4 bit, 1 bit)
- Operating Voltage: 3.30 VDC \pm 5 %
- Radio Specifications: 2.4-2.4897GHz (FCC, ETSI, TELEC)
5.15-5.85GHz (FCC, ETSI, TELEC)
- Radio Transmit Power (Typical):
 - 18 dBm (802.11b/g)
 - 16 dBm (802.11a)
- Temperature: -20 to +70 °C
- Packaging: 24 x 46 x 4.1 mm

SX-SDPAG & SX-SDPBG

SDIO SMT Modules for 802.11a/b/g resp. b/g

The SX-SDPAG is an 802.11a/b/g Radio/Baseband SDIO SMT Card for OEM embedded applications, like the SX-SDPBG, which only uses the WLAN standards 802.11b/g. Both modules have the same features as SX-SDCAG to support a high quality, easy and fast implementation.

- Electrical Interface: SDIO V 1.1 (4 bit, 1 bit)
- Operating Voltage:
 - SX-SDPAG: 3.30 VDC \pm 5%
 - SX-SDPBG: 3.30V, 1.8V, 1.2V
- Packaging:
 - SX-SDPAG: 56 PINs, 15 x 15 x 2.55 mm
 - SX-SDPBG: 7.4 x 8 x 1.1 mm



SX-560-2701



SX-10WAN



SX10-WAG and SX10-WG

Wireless LAN



SX-560-2701

Intelligent programmable WLAN Module

Intelligent, compact and low-cost WLAN module (IEEE 802.11a/b/g) which consumes very low power. Therefore it is ideal for battery-operated devices. Because of its broad range of services and its extensive security functions, it is suitable for almost any WLAN application.

- Device Interface:
 - 2x Serial Port (UART with TXD, RXD, RTS and up to 921.6 Kbps on each Port; GPIO are configurable as DTR, DSR and DCD on Port 1)
 - UART Console Port is available for configuration
 - 1x USB-1.1 Host Port (12Mbps)
- Network Interface:
 - IEEE 802.11a/b/g (54/11Mbps)
- WLAN Security:
 - WPA2(-PSK), WPA(-PSK) and WEP;
 - 802.1x Authentication with EAP and all major EAP types

Additional Features:

- Linux programmable
- 9 General Purpose I/Os (GPIO)
- 200 MHz 32 bit processor, 16 MB RAM and 8 MB flash memory
- Very low power consumption (3.3 V \pm 5 %, max. 460 mA plus Wake-up function)

SX-10WAG/WG/WAN

Mini PCI radio modules, that provide superior features

The SX-10WG, SX-10WAG and SX-10WAN are high quality mini-PCI wireless LAN modules, that are designed specifically for OEM embedded applications. They are used to add 802.11b/g (SX-10WG), 802.11a/b/g (SX-10WAG) or 802.11a/b/g/n (SX-10WAN) capabilities to devices where the higher-level network processing is done in the OEM device's processor. Unlike generic mini-PCI modules, that are intended for use in laptops, the SX-10WG, SX-10WAG and SX-10WAN meet the specific requirements of demanding OEMs for features, quality, and support.

Support for SX-10WG / SX-10WAG / SX-10WAN

Windows drivers from Silex.

The SX-10WG and SX-10WAG drivers allow you to use the SX-10WG/WAG as a standard 802.11 wireless card on a Windows 2000 or Windows XP (including Windows XP embedded) computer system, with configuration via the Windows Control Panel.

Open Source Linux drivers for the SX-10WAN

IMPORTANT NOTE: This link is provided for your convenience only. This driver is free software, that is not supported by Silex or Rutronik.

Drivers can be downloaded at:

<http://wireless.kernel.org/en/users/Drivers/ath9k>



Telic
Telematik & Telemetrie

Telit wireless solutions

Fastrax

GSM/GPRS/EDGE/UMTS products

Terminals

Type	Same form factor	Programmable	Other features
GT863-PY	x	Python	
GT863-3GG	x		UMTS Global version. 12-channel GPS
GT864-QUAD	x		
GT864-PY	x	Python	
UT864-E / GT864-3G	x		UMTS European version
CT63	x	Option	Cinterion based. Low power mode
Q26	x	Option	Sierra Wireless / Wavecom based. Low power mode

Gateway

Type	Same form factor	Description
GG863-SR	x	Short range to GSM/GPRS gateway. Linux OS.

Telematic

Type	Same form factor	Other features
SBC3		CAN and 1-Wire* interface as option. E-certification.
Professional BC		CAN and 1-Wire* interface. Up to 19 I/O. E-certification.
uTrace03e		Fully programmable. Consumer and Automotive versions

Modules GSM/GPRS

Type	SIM holder	GPS	Programmable	Same form factor	Other features
GM862-GPS	Yes	Yes	Python	x	
GE863-GPS	No	Yes	Python	x	BGA
GE863-PRO ³	No	No	Linux OS		BGA, Embedded ARM 9
GE864-QUAD V2	No	No	Python	x	BGA
GE864-QUAD Automotive V2	No	No		x	BGA, Automotive
GE864-QUAD Atex	No	No	Python	x	BGA, Atex
GE865	No	No	Python		BGA
GL865-DUAL	No	No	Python		Dual band, LCC package
GC864-QUAD V2	No	No	Python	x	
GC864-QUAD V2 SIM	Yes	No	Python	x	

UMTS/GSM/GPRS/EDGE

Type	SIM holder	GPS	Programmable	Same form factor	Other features
UC864-E	No	No		x	GSM Quad band, UMTS 2100 MHz, HSDPA
UC864-E-DUAL	No	No		x	GSM 900/1800 MHz, UMTS 900/2100 MHz, HSDPA
UC864-E-AUTO	No	No		x	GSM Quad band, UMTS 2100 MHz, HSDPA
UC864-WD	No	No		x	GSM 900/1800 MHz, UMTS 900/2100 MHz, No voice
UC864-G	No	Yes		x	GSM Quad band, UMTS 850/1900/2100 MHz, HSDPA



GT863



GT864 / UT864 / CT63 / Q26



GSM/GPRS /UMTS terminals

GT863-PY

- Supply voltage range: 9 – 24 VDC
- Dimensions: 107 x 64 x 33 mm
- Temperature range: -30 °C to +75 °C
- 4 I/O General Purpose I/O or IIC Bus
- D-Type 9 pin connector for RS-232 communication
- On board SIM card holder

Accessories

Type	Order number	Description
Power supply	WIREAC1091	Power supply for GT863 & EZ-10
Cable	WIREAC1087	RS232 cable

GT864-QUAD, GT864-PY

- Supply Voltage Range: 5 – 36 VDC
- Dimensions: 77 x 67 x 26 mm
- Temperature range: -30 °C to +75 °C
- 4 General Purpose inputs (GT864-PY only)
- Analog audio (GT864-QUAD only)
- 1 A/D converter (GT864-PY only)
- 3x LED for status indication
- CE, FCC approval
- E-mark

Accessories

Type	Order number	Description
Power supply	WIREAC1090	Power Supply 230V with mini western connector
Power cord	WIREAC1089	Power cord with 6 pin mini western connector
Cable	WIREAC1087	RS232 cable

UT864 / GT864-3G Terminal

- Terminal with:
 - UMTS European bands
 - Quad band GSM/GPRS/EDGE
 - Up to 7.2 Mbit/s HSDPA data rate
 - USB 2.0 full speed interface
- Power supply: 5 – 32 VDC
- Modes of operation:
 - AT commands on UART, data on USB
 - AT commands on USB, data on UART
- CE approval
- E-mark

GT863-3GG

- GSM/UMTS and GPS
- UMTS/HSDPA (7.2 Mbps), 850 / 1900 / 2100 MHz
- Quad band GSM/GPRS
- EDGE multi-slot class 12
- Supply voltage range: 5 – 30 VDC
- Temperature range: -20°C to +65 °C
- 3 GPIOs, 1 ADC
- RS232 and mini USB interface
- GPS sensitivity with active antenna: -157 dBm
- 12-channel GPS



CT63, Q26



GG863-SR

GSM/GPRS/UMTS terminals



CT63

- Cinterion based, supports Cinterion AT-commands
- Connectors identical to the connectors from the TC35/MC35 terminal
- Quad Band GSM/GPRS
- TCP/IP stack, UDP, SMTP, FTP
- RS232 serial port
- USB 2.0 interface
- Low Power Mode (1 mA with GPRS connect)
- 1 Status LED (GSM)
- Multiplex Drivers for Windows and Linux
- 5-32 V DC supply
- Extended temperature range: -40 °C to +80 °C
- CE approval RoHS compliant

Optional features for CT63

- EDGE
- Programmable Java version (with 2 status LEDs)
- I/O variants available
- Audio interface
- SPI
- I²C
- USB host powered: 5 Volt/500 mA

Q26

- Supports Wavcom and SonyEricsson AT-Commands
- Sierra Wireless based
- Quad Band
- TCP/IP stack, UDP, SMTP, FTP
- RS232 serial port and USB 2.0 interface
- Multiplex Drivers for Linux
- Low Power Mode (1mA with GPRS connect)
- 5-32 V DC supply

- Temperature range: -30 °C to +80 °C
- CE approval, RoHS compliant

Optional features for Q26

- UMTS
- EDGE
- Open AT[®] Programmable (with 2 status LEDs)
- I/O variants available
- Audio
- SPI
- I²C

Short range GSM/GPRS gateway

GG863-SR

The GG863-SR brings together the GSM/GPRS and short-range technology, hosting programmable GE863-PRO³ and any short-range module from Telit. The behavior of the gateway can be customized through the embedded Linux development environment and dedicated libraries for GSM and short-range.

- Quad band EGSM
- Supply voltage range 5-36V DC
- Linux OS
- Easy user interface (web server)
- Short Range RF module (Mesh, ZigBee, Wireless M-bus)
- RJ11 multipurpose 4pins (2pins UART debug for ARM9, 2pins UART for ME50-868 module)



GSM/GPRS/UMTS modules



Useful features when using Telit modules

Telit Infinita Services

Telit Infinita Services is the new service concept from Telit Wireless Solutions. The primary goal of this offering is to simplify m2m solution deployment and maintenance of device software. Telit Infinita Services support customers in managing device populations throughout their lifetime via a powerful back-end solution.

As the m2m space becomes increasingly competitive, our customers have an apparent need to offer innovative new solutions, that can clearly differentiate them from the competition. Telit enables an entirely new grade of service experience, providing a strong advantage over conventional m2m offerings.

The initial set of Telit Infinita Services will focus on extending the life of deployed products by updating and maintaining the optimum firmware version in the field, as well as providing an extended Hardware Warranty plan to support the end customer's warranty terms for up to five years. The first two service offerings are:

- Premium FOTA Management
- Extended Hardware Warranty

An additional benefit for those clients using the dual core Telit GE863-PRO³ module, is the possibility to implement bug fixes or correct malfunctions over-the-air as well as their application firmware.

Python®

Python is a high-level programming language first released by Guido van Rossum in 1991. Python is often characterized as minimalist, although this only applies to the core language's syntax and semantics; the standard library provides the language with a large number of additional libraries and extensions.

Python is a remarkably powerful dynamic programming language, that is used in a wide variety of application domains.

Some of its key distinguishing features include:

- Extremely clear, readable syntax
- Strong introspection capabilities
- Intuitive object orientation
- Natural expression of procedural code
- Full modularity, supporting hierarchical packages
- Exception-based error handling

The core benefits of Telit's programming solution with Python are:

- No license fees or dependence on manufacturers' technology
- Built-in custom modules dedicated to m2m
- Operating efficiently with low power processor = low power consumption
- Reduces total cost of the module
- Ready to use



GSM/GPRS/UMTS modules

Other features with Telit GSM modules

■ Telit - owned protocol stack

Developed and maintained by and under total control of the company's R&D team

■ EASY SCAN®

GSM network scan without SIM card inserted

■ Jamming Detect & Report®

Jamming Detection of the GSM network with subsequent reporting via GPIO/serial connection and/or network

■ EASY GPRS® & FTP

■ Enhanced integrated TCP/IP stack

■ FTP client

■ Built-in firewall

■ Running AT commands remotely

■ AT commands can be run on a remote module via SMS or via TCP.

■ Then using TCP the module can act as server or client.

■ Event monitor

■ This service allows a user to associate an AT command to a specified event monitored from the module.

■ This service can be used supervise events like battery voltage, DTR signal (to supervise external equipment), network roaming status, GPRS context deactivation, module start-up and I/O pins.

New products 2011

The year 2011 for Telit will be characterized primarily by the launch of new EDGE products in BGA form factor as well as with the connector. In addition, Telit will introduce several new 3G products with HSPA 7.2 Mbps DL / 5.76 Mbps UL capabilities, and with different combinations of bands, depending on the market need. These products will be with or without GPS and will also be available in BGA form factor, as well as with board to board with the connector.



GM862



GE863

GSM/GPRS modules



GM862-GPS

- Supply voltage range: 3.22-4.5 V DC
- Dimensions: 43.9 x 43.9 x 6.9 mm
- 50-pin connector
- Temperature range: -40°C to +85°C
- On-board SIM card holder
- 13 I/O ports maximum
- Analog audio
- 1 A/D converter
- Python interpreter

GPS receiver, SiRFstarIII

- High sensitivity GPS, up to -159 dBm
 - Fast TTFF
 - Hot start: <3 s
 - Warm start: <35 s
 - Cold start: <35 s
- 200.000 + correlators
- NMEA 0183 output format
- Date WGS-84
- SBAS (WAAS and EGNOS) support
- Dedicated GPS AT commands

GM863-GPS

- Supply voltage Range: 3.22-4.5 V DC
- Dimensions: 41.4 x 31.4 x 3.6 mm
- BGA package
- Temperature range: -40 °C to +85 °C
- SIM on chip (GE863-SIM only)
- 18 I/O ports maximum
- Analog audio
- 3 A/D plus 1 D/A converters
- Python interpreter (-PY only)

GPS receiver, SiRFstarIII

- High sensitivity GPS, up to -159 dBm
- Fast TTFF
 - Hot start: <3 s
 - Warm start: <35 s
 - Cold start: <35 s
- 200.000 + correlators
- NMEA 0183 output format
- Date WGS-84
- SBAS (WAAS and EGNOS)
- Dedicated GPS AT commands



GSM/GPRS modules



GE863-PRO³

The GE863-PRO³ is an innovation to the quad-band, RoHS compliant GE863 product family which includes a powerful ARM9™ processor core exclusively dedicated to customer applications. The concept of combining a powerful processor core with the GSM/GPRS engine allows developers to host their application directly.

The GE863-PRO³ was designed to simplify connectivity through the availability of interfaces such as SPI, I²C, SD/MMC and USB (Host/Device). Telit offers a vast collection of reference designs enabling PRO³ with external peripherals. With the use of LINUX (optional), developers have access to an extensive library of drivers for different peripherals and to complete development environments.

- Supply voltage range: 3.22 - 4.5 V DC
- Dimensions: 41.4 x 31.4 x 3.6 mm
- BGA package
- Temperature range: -30 °C to +80 °C
- 88+9 general purpose I/O ports
- Analog audio
- 4 A/D with A/D trigger and 6 PWM D/A converters
- 1 USB device and 2 USB host
- 2 SPI buses, each with up to 7 slave devices
- 1 IIC interface
- 1 SSC (I2S) digital audio interface
- 1 SD/MMC card and SAM/SmartCard ISO7816 interface
- 1 image sensor interface ITU-B 601/656
- 6 USARTs and 1 UART
- ARM processor
 - ARM9 core 220 MIPS
 - Independent from GSM engine
 - Linux operating system (optional)
 - Cross compilation on PC
 - 64 MB SDRAM plus 128 MB Flash



GE864-QUAD V2



GC864



GC864 with SIM holder

GSM/GPRS modules



GE864-QUAD V2

- Supply voltage range: 3.22 – 4.5 VDC
- Dimensions: 30 x 30 x 2.8 mm
- BGA package
- Temperature range: -40 °C to +85 °C
- 10 I/O ports maximum
- Analog audio (balanced)
- Digital audio
- 2 A/D plus 1 D/A converters
- Telephony emergency call
- Python script interpreter

GE864-AUTOMOTIVE V2 is a rugged version of GE864-QUAD

- Supply voltage range 3.25 – 4.2 VDC
- Temperature range: -40 °C to +85 °C
- Environmental tests
 - ISO 16750-1:2006
 - ISO16750-3:2007
 - ISO16750-4:2010
- PIN Protection
 - ESD protection level 4
 - Contact up to +4 kV
 - Air up to +8 kV
 - Contact antenna pin up to +-15 kV
 - All pins have HBM filtering (EMC protection)
 - 9 I/O ports maximum
 - 2 A/D converters
 - Analog audio (balanced and unbalanced)

GE864-QUAD ATEX V2

- Supply voltage range: 3.25 – 4.2 VDC
- Dimensions: 30 x 30 x 2.8 mm
- Temperature range: -40 °C to +85 °C
- 9 I/O ports maximum
- 2 A/D plus 1 D/A converters
- ATEX integration parameters:
 - $U_i=4.2$ V, $I_i=2.5$ A, $C_i= 27.5$ μ F, $L_i=55.2$ nH
 - ATEX EC Type examination approval as intrinsic safe component “i”  II 1G Ex ia IIC T4
- PIN Protection
 - ESD protection level 4
 - Contact up to ± 4 kV
 - Air up to ± 8 kV
 - Contact antenna pin up to ± 15 kV
 - All pins have HBM filtering (EMC protection)
- Python script interpreter

GC864-QUAD V2, GC864-QUAD V2 SIM

- Supply voltage range: 3.22 - 4.5 VDC
- Dimensions: 30 x 36.2 x 3.2 mm
- 80 pin connector
- GSC antenna connector
- SIM card holder (GC864-QUAD V2 SIM)
- Temperature range: -40 °C to +85 °C
- 10 I/O ports maximum
- 2 A/D plus 1 D/A converters
- Python script interpreter



GSM/GPRS modules



GE865-QUAD

With its ultra-compact design and extended temperature range, the Telit GE865 product line is the perfect platform for high-volume m2m applications and mobile data devices. Additional features such as integrated TCP/IP protocol stack and serial multiplexer extend functionality of the application at no additional cost.

The GE865 makes it possible to run the customer's application inside the module using Python Script Interpreter, thus making it the smallest, complete platform for m2m solutions.

- Quad band EGSM 850 / 900 / 1800 / 1900 MHz
- Supply voltage range: 3.22 – 4.5 VDC
- Dimensions: 22 x 22 x 3 mm
- BGA package
- Temperature range: -40 °C to +85 °C
- 10 I/O ports maximum
- 2 A/D plus 1 D/A converters
- Python script interpreter

GL865-DUAL

GL865-DUAL is a dual band 900/1800 GSM/GPRS device in LCC castellation packaging with extremely low power consumption, extended temperature range and compact profile. The low profile and small size of SMT package combined with very low power consumption enables the design of very compact applications with increased autonomy. Since connectors are eliminated, the solution cost is significantly reduced compared to conventional mounting.

- Dual-band EGSM 900 / 1800 MHz
- Dimension 24.4 x 24.4 x 2.7 mm
- Supply voltage range: 3.22 – 4.5 VDC
- Temperature range: -40 °C to +85 °C
- 8 I/O port maximum
- Analog and digital audio
- 2 A/D plus 1 D/A converter
- Python script interpreter



UC864-E



UC864-E-DUAL



UC864-G

GSM/UMTS/HSDPA/EDGE/GPRS modules



UC864

UC864 is designed to be fully compatible with the GSM/GPRS and CDMA modules in the compact, unified form factor family from Telit. All modules support GSM/GPRS/EDGE.

UC864-E for the European market is with a single band UMTS/HSDPA (2100 MHz) radio and quad band GSM.

UC864-E-DUAL supports dual band GSM/GPRS/EDGE (900 / 1800 MHz) and dual band UMTS/HSDPA (900 / 2100 MHz).

UC864-G has a triple band UMTS/HSDPA (850 / 1900 / 2100 MHz) radio for the global market, quad band GSM/GPRS/EDGE and embedded GPS.

UC864-WD is a data only solution where HSDPA and voice is not required. UC864-WD is dual band GSM/GPRS/EDGE (900 / 1800 MHz) and dual band UMTS (900 / 1800 MHz).

UC864-E-AUTO - Quad band GSM/GPRS/EDGE and single band UMTS/HSDPA (2100 MHz). USB (2.0 full speed), UART and PCM interfaces. Digital audio, GPIOs, D/A- and A/D-converters.

- HSDPA
 - Downlink up to 7.2 Mbps
 - Uplink up to 384 kbps
- UMTS/WCDMA
 - Download/Uplink up to 384 kbps
- EDGE, multi-slot class 12
 - Downlink up to 236.8 kbps
 - Uplink up to 118 kbps
- GPRS, multi-slot class 12
 - Downlink up to 85.6 kbps
 - Downlink up to 42.8 kbps
- Dimensions:
 - 30 x 45 x 4.8 mm
 - (UC864-G, UC864-E-DUAL, UC864-WD)
 - 30 x 36.2 x 4.8 mm (UC864-E)
- Temperature range: -30 °C to +80 °C
- Supply voltage range: 3.4 – 4.2 V DC
- 22 I/O ports maximum
- USB 2.0 full speed interface
- 3 A/D plus 1 D/A converters
- Available modes of operation
 - AT commands on UART & data on USB
 - AT commands on USB & data on UART

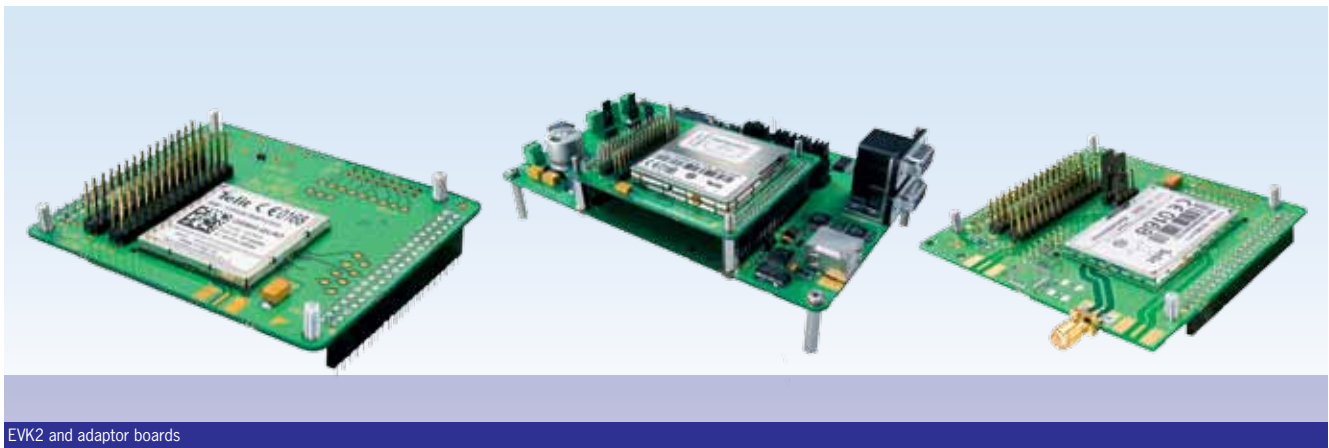

EVK2 and adaptor boards

Evaluation/development kit



EVK2 Evaluation Kit

The Telit Evaluation Kit EVK2 provides a robust, future-proof and flexible environment for rapid development of applications for the full range of GSM/GPRS, UMTS/HSDPA and CDMA module families, dramatically reducing the time to market. The kit is comprised of a motherboard, on top of which an adaptor board with the related module is plugged. This concept allows using it across the boundaries of various form factors and product generations, now and in future.

EVK2 is a tool for:

- Developing applications based on Telit modules via AT commands through serial ports
- Programming and updating of modules
- Debugging module based applications
- Implementing simple applications (stand-alone function) by executing scripts using a Python interpreter equipped module without the need for an external microprocessor
- The power supply has three options:
 - Laboratory setup, +3.8 V fixed supply
 - Automotive setup, +5 to 40 V supply
 - Portable setup, rechargeable Li-Ion battery pack

The complete tool consists of motherboard (EVK2), interface board and GSM module. The GSM module is included on the interface board for BGA versions.

EVK-PRO³ Evaluation Kit

The Telit Evaluation Kit PRO³ provides a ready, future-proof and flexible environment for rapid development of applications with the GE863-PRO³ GSM/GPRS engine including ARM9 processor core, dramatically reducing the time to market. The kit is formed by a motherboard, on top of which an interface (adaptor board) with the GE863-PRO³ module is plugged. This concept allows using it across the boundaries of various form factors and product generations, now and in future.

EVK-PRO³ is a tool for:

- Developing applications based on GE863-PRO3 via AT commands through serial ports
- Programming and updating of modules
- Debugging module based applications
- Implementing simple applications (stand-alone function) by executing scripts over a Python interpreter (only GE863- PRO³ with Linux OS) or in C/C++ without any external microprocessor.
- Input power supply:
 - Automotive setup, +5 to 40 V supply
- All 88+9 GPIO is available on the interface board
- 4 x RS-232 serial ports
- 2 USB host and 1 USB device
- ISO7816 and SD/MMC interface

The complete tool consists of motherboard and the interface board with GSM module.

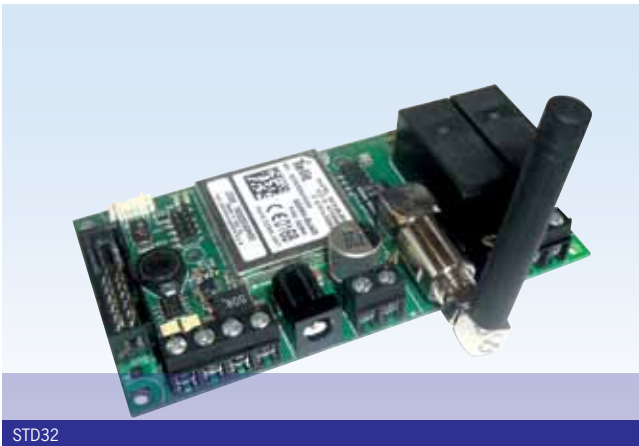

STD32



STD35

Telemetry products



Telemetry device STD32

Complete telemetry device for professional use with camera interface sending photos via e-mail in alarm situations. The webserver application enables you to configure the STD32 online via the internet as well as to trigger a photo from the connected camera.

- Easy control via SMS or internet (GPRS)
- Camera interface
- Pictures via e-mail
- Alarm messages via SMS or e-mail
- 5 alarm SMS and e-mail addresses
- 2 digital control outputs (6 A at max. 230 V)
- 2 digital inputs
- Power supply: 5 – 32 VDC
- 5 LED's for status information
 - Extension connector for system integrators
 - CE approval

Camera for STD32/STD35

- Resolution up to 640 x 480 pixels
- Infrared light for dark environment
- 2.5 m cable

Accessories

Type	Order number	Description
Box for STD32	WIREAC1102	Plastic box for STD32
Camera	WIREAC1273	Camera for STD32
Powercord	WIREAC1244	Powercord for STD32, STD35
Power supply	WIREAC1218	Power supply 230V AC for STD32, STD35

Telemetry device STD35

- Autonomous telemetric module
- 5 inputs for level surveillance by opto couplers
- 5 outputs
- Water protected 65 housing
- Screw terminals inside for connections
- ARM7 based
- Camera interface
- Webserver and E-mail functionality
 - Remote configuration
 - Remote camera access
- Battery backup
- UMTS option with video in real time
- DOTA ready
- Configuration and diagnostic tool





SBC3



Professional BC

Telematics products



Standard Board Computer (SBC3)

The GSM/GPS telematics Black Box SBC3 consists of a highly flexible AVL system within a robust water protected housing. The internal screw clamps allow a project specific configuration of connection cables to fulfil all relevant customer needs in terms of connectivity to the car. The internal back-up battery, the optional CAN and 1-wire interfaces and the intelligent roaming concept are only a few features of SBC3.

- Internal screw terminals (optionally pluggable)
- 1x RS232 port for diagnostics
- 2x digital inputs
- 1x analog input
- 1x digital output
- 3-level watchdog
- Status/diagnostic LED's
- Software update over the air (DOTA)
- LiPol. battery backup
- 7 to 32V supply input range
- Temperature range -30 °C to +75 °C
- Optional available – SBC3 CAN
 - 1x CAN-Interface (FMS-support)
 - 1x RS232 port for diagnostic
 - 1x 1-Wire® interface
 - E-certificate for automotive usage

Professional BC

The Telic PBC is the right GSM/GPS tracking device for fleet management, security applications and logistics projects. Water protected housing, CAN-Bus, 1-wire, three serial interfaces, integrated LiPol battery, input voltage range up to 60V and all relevant approvals for the use in vehicles are only a few telematics features of the PBC black box.

- CAN-bus interface
- Supply voltage range (7 to 60V)
- UP to 19 ESD protected I/Os
- Flexible I/O configuration
- 3 RS232 interfaces
- 50 channel GPS receiver with Assisted GPS
- Mileage (km) counting via GPS or external odometer pulses
- Very high processing power and large storage memory
- Internal extension options for projects
- Backup battery (LiPolymer) for uninterrupted power supply
- 3-level watchdog controller ensures always-up functionality
- LED status control
- Operating temperature -30 °C to +75 °C
- Software update (DOTA) over the air via GPRS / FTP
- E-Certificate for automotive usage



Picotrack



uTrace03 Evaluation Kit

Telematics products



Telic Picotrack

- Ultra small size – only 40 grams
- Stand-alone unit incl. GSM / GPS antenna and rechargeable LiPolymer battery
- High sensitivity GPS-tracking module, supports SuperSense Indoor GPS and wireless assisted GPS
- Very large internal ceramic GPS patch-antenna, increasing the GPS sensitivity even further
- Easy to recharge via USB connector
- The intelligent power management allows several sleep configurations for optimal standby time
 - Max. reactive sleep time: many weeks
 - Continuous GSM & GPS operation time: 2 hours (power management activated: several days)
- Software update over the air via GPRS / FTP
- The internal watchdog concept guarants a reliable performance and the low battery warning informs user (LED) and control centre
- LED status control
- Tracking events by time period and direction changes.
- Operating temperature: -20 °C to +60 °C
- Geofencing



Track & Trace platforms



uTrace03 Track&Trace platform

Fastrax Track&Trace Platform is an adaptable OEM tracking device with advanced tracking software features

- Hardware can be customized
- Default tracking software can be customized
- Custom software development tools available
- Telematics device with GPS navigation and GSM/GPRS communication
- Complete stand-alone design, dimensions: 55 x 90 x 10 mm
- Reliable GPS performance, high sensitivity -156 dBm (navigation)
- Quad-band GSM/GPRS modem for worldwide coverage
- On-board GPS and GSM antennas
- Battery powered operation with minimum setup
- Controlled by the GPS core processor – no need for extra CPU
- HW assembly options for optimum BOM/cost
- Very low power consumption, sleep mode <math><20\mu\text{A}</math> @ 3.8 VDC
- Wide temperature range
 - GPS: -40 °C to +85 °C, GSM: -30 °C to +75 °C
- Easily extendable in HW through the system connector
- Easily extendable in SW using iSuite3 SDK + uTrace Toolkit

Product	Description	Power consumption	Dimensions (mm)	Main I/O ports	Photo	Note
FASTRAX 300-Series FOR HIGH PERFORMANCE						
IT310	Small and highly sensitive GPS receiver module	75mW@3.0V	13.1 x 15.9 x 2.3	1 PPS Wake-up interrupt Battery back-up		Adaptive Trickle-Power. Push-to-Fix. Extended ephemeris. Static filter. Track smoothing.
IT300	Highly sensitive, pin-compatible with MP family GPS receivers	75mW@3.0V	16.2 x 18.8 x 2.3	1 PPS Wake-up Battery back-up		Fastrax IT MP compatible. Adaptive Trickle-Power. Push-to-Fix. Static filter.
FASTRAX 300-Series WITH INTEGRATED ANTENNA						
UP300	Integrated patch antenna & ext. antenna connector	85mW@3.0V	19 x 27 x 7.2	1 PPS Main power supply; Back-up power supply		Adaptive Trickle Power. Push-to-Fix. Extended ephemeris. Static filter. Track smoothing

GPS modules, 300-Series



IT300

Extremely compact member of the multi-platform family of OEM GPS Receiver Modules features high performance, cost-effective design making it very suitable for all NMEA types of applications.

- Tiny form factor – 16.2 mm x 18.8 mm x 2.3 mm
- NMEA & SiRF binary protocols
- GPIO available for custom purposes
- WAAS/EGNOS/MSAS support

IT310

OEM receiver for many applications.

- Tiny size – 13.1 mm x 15.9 mm x 2.3 mm
- NMEA & SiRF binary protocols
- GPIO available for custom purposes
- External clock input
- Timesync input
- Wake-up interrupt input

UP300

Fastrax UP300 OEM GPS receiver module with embedded GPS antenna and antenna switch for external antenna

- Tiny form factor –
19 mm x 27 mm x 7.2 mm
- Embedded patch antenna
18.4 x 18.4 x 4.2 mm
- NMEA & SiRF binary protocols
- External GPS antenna connector, automatic antenna sense and switching

Fastrax UP300: system cable and mother board connector

The 10 cm system cable including system connectors on both ends is designed to be used with the Fastrax UP300 GPS antenna receivers.

Ordering information

Order number	Part number	Description
WIREAC1147	CABLE UP300	Adapter cable 08SUR-32S/08SUR-32S



GPS modules, 400-Series



IT430



Fastrax IT430, based on new generation SiRFstar IV architecture and SiRFaware technology, offers a range of new benefits that speed the inclusion of location-aware features in battery operated consumer devices. The complete Fastrax IT430 GPS module is packed into a tiny casing for easy fitting into various handheld or other battery powered devices. Fastrax IT430 features a miniature form factor of only 9.6 x 9.6 x 1.85 mm, which makes it one of the smallest complete GPS modules available on the market. With the included TCXO, RTC and SAW filter, the amount of required external components is reduced to a minimum.

Fastrax IT430 is especially well suitable for battery operated devices using 1.8 V internal power regulation. The low-power GPS module consumes only 56 mW at 1.8 V in full operation mode. With SiRFAware it consumes only 500uA in average. The small size and low power consumption combined with ultra-high sensitivity, allows easy utilization in a variety of applications, including the smallest battery-operated consumer devices.

With its new innovative standby mode, Fastrax IT430 activates itself autonomously from time to time in order to maintain awareness of its location at all times. As a result, updated location information is available almost immediately when activated, without compromising battery life.

The module supports also connectivity to optional external sensors for Dead Reckoning like 3D-accelerometer on dedicated DR_I²C bus.

- Miniature size: 9.6 x 9.6 x 1.85 mm
- Ultra high sensitivity:
 - -147 dBm (cold start)
 - -163 dBm (tracking)
- Advanced power modes
- Low Power Consumption: 56/68 mW@1.8 V
- 500 μ A average power consumption with SiRF Aware
- 48 channels
- Host port configurable to UART, SPI or I²C
- NMEA protocol, switchable to OSP binary
- 1PPS output
- SBAS/WAAS support
- AGPS Support
- Embedded client and server generated extended ephemeris
- Dedicated I²C port for external sensors
- CW Jammer remover, track and remove up to 8 CW
- SiRFstarIV, GSD4e GPS chip

Product	Description	TTF	Sensitivity	Power consumption	Dimensions(mm)	Protocols	Chipset	Main I/O ports	Photo	Note
Fastrax 500series										
IT500	MP family form factor	<35s	-165 dBm	75mW@3.0V	16.2 x 18.8 x 2.3	NMEA	MediaTek MTK3329	1 PPS 2 serial ports (NMEA, RTCM)		22 tracking + 66 acquisition channels Fix rate up to 10 Hz
IT520 (IT520U)	Tiny form factor	<35s	-165dbm	75mW@3.0V	10.4 x 14.0 x 2,3	NMEA	MediaTek MT3329	1 PPS 2 serial ports (USB 2.0)		22 tracking + 66 acquisition channels. Fix rate up to 10 Hz
UP501	Embedded antenna	<35s	-165dBm	75mW@3.0V	22 x 22 x 8	NMEA	MediaTek MT3329	1 PPS, 2 serial ports		22 tracking + 66 acquisition channels. Patch antenna

GPS modules, 500-Series



GPS modules

Fastrax IT520 and IT500 GPS receiver modules offer the best performance and sensitivity among any GPS modules. Both modules have same features and specifications, like 14 days predicted A-GPS, up to 10Hz update rate, amazing signal acquisition and record breaking navigation sensitivity. The only difference is size. IT520 is the smallest module in the Fastrax IT500 series of GPS receivers with a footprint of only 10.4 x 14.0 x 2.3mm while the IT500 has Fastrax Multiplatform footprint, which means that the same hardware design can be used for Fastrax IT300 modules as well. Fastrax IT520 and IT500 are built with the market-leading GPS chip from Mediatek, MT3329. With cold start sensitivity of -148dBm it is possible to acquire satellite signals and start navigating in places where competing modules do not even get the first fix. Once the receivers have a fix, the ultimate navigation sensitivity of -165dBm ensures the satellite signals will be received even in most dense and difficult urban areas.

- Supply voltage range: 3.0 – 4.2 V
- Up to 10 Hz fix update rate
- Jammer detection and removal
- WAS/EGNOS support
- Predicted A-GPS for 14 days
- USB 2.0 connection on IT520U

Antenna modules

Fastrax UP501 is specially designed to make application design easy. It eliminates the need for antenna selection and tuning, speeding up the time-to-market for the device. The integrated patch antenna of 18 x 18mm provides very good performance, and it is already tuned for a plastic enclosure. In order to support stable mounting, there are built-in PCB-mounting flanges on the shield for firm soldering, to survive even tougher environments.

Fastrax UP501 enables extremely high navigation performance due to the navigation sensitivity of -165dBm. This sensitivity can also be utilized on 10 Hz update rate, making UP501 ideal also for motor sports applications. Fastrax UP501 comes in different variants: UP501B with an on-board backup battery, as well as UP501R with RS232 level serial port and back-up battery and UP501D with a dual SAW-filter. The dual SAW-filter is targeted for telematics applications where a radio transmitter is placed close to the GPS receiver. This reduces the risk of EMC issues when high-gain systems (GPS receiver) are in strong signal field (radio transmitter).

- Supply voltage range: 3.0 – 4.2 V
- Up to 10 Hz fix update rate
- Jammer detection and removal
- WAS/EGNOS support
- Predicted A-GPS for 14 days
- 3 versions:
 - UP501B with back-up battery
 - UP501R with back-up battery and RS232 level serial port
 - UP501D with dual SAW-filter

Product	Description	TTF	Sensitivity	Power consumption	Dimensions (mm)	Protocols	Programmable	Chipset	Chn.	Main I/O ports	Photo	Note
FASTRAX 03-Series FOR PROGRAMMABILITY AND LOW POWER												
IT03	Programmable with data logger.	<36s	-156 dBm	100mW@2.7V	22 x 23 x 2.9	NMEA & iTalk	Yes	Atheros (uN8021RF, uN8130 BB)	12	1 PPS		Programmable with iSuite MP SDK

GPS modules, 03-Series



IT03

The IT03 offers market leading programmability enabling benchmarking of the total cost of the product.

- Tiny PCB form factor – 22 mm x 23 mm x 2.7 mm
- Basic A-GPS support
- iTALK and NMEA0183 protocols
- Kalman Navigation
- Supports remote software updates
- Extensive support for external sensors
- Versatile interface ports
- Accurate 1PPS timing output
- IT03/16 – 16MBit Flash Memory
- Datalogger, up to 70,000 datapoints



Fastrax Mini Evaluation Kit

Easy evaluation of Fastrax receivers

The Fastrax Mini Evaluation Kit is equipped with a 40 pin socket for Fastrax application boards and a JST system connector for Fastrax UP300 antenna modules.

Ordering information

Application board featuring desired GPS receiver and related documentation has to be ordered as a separate item.



Fastrax application boards

Fastrax has developed application boards for all Fastrax IT modules in order to make evaluation easier.

Each application board is also a reference design for its appropriate Fastrax IT module.



SE867-AGPS



EVB-867

GPS modules



SE867-AGPS

The SE867-AGPS is the smallest module in Telit portfolio, and the first GPS standalone module featuring state-of-the-art GPS characteristics, with the high quality and great support that usually accompany Telit products.

The low profile and small size of the unique BGA package for the SE867-AGPS enable the design of extremely compact applications. Since connectors are eliminated, the solution cost is significantly reduced compared to conventional mounting.

With its ultra-compact design and extended temperature range, the Telit SE867-AGPS is the perfect module for high-volume m2m applications and mobile data devices.

Requiring only 2 layers for PCB design and little integration effort for external components, Telit SE867-AGPS represents the ideal solution in terms of total cost effectiveness and time-to-market readiness.

Equipped with a powerful yet power saving baseband processor, SE867-AGPS provides all the GPS information via NMEA standard protocol on serial interface.

Applications requiring extremely quick FIX can efficiently retrieve the correct position within two seconds, by means of assisted GPS and pre-fetch ephemeris features.

- 44 channels
- WAAS, EGNOS and MSAS
- A-GPS ephemeris file injection
- UART. 4.8 – 230k baud rate
- Low power consumption 65 mW@3.0 V, tracking
- Sensitivity:
 - Cold start acquisition: -144 dBm
 - Assisted acquisition: -155 dBm
 - Tracking: -160dBm
- Form factor: 18 x 18 x 3.5 mm
- Temperature range: -30 to +85 °C

The EVB-867 is the evaluation kit of SE867-AGPS.

The evaluation kit consists of a single board with:

- SE867-AGPS module
- Mini-USB connector for power supply and data communication with a PC
- FTDI chip for USB to UART conversion
- SMA RF connector for external active antenna or instrument connection
- DIP switches for configuration options selection

The FTDI chip allows using a common mini USB cable to transfer data avoiding the need for a RS232 connection and reducing the data transmission and the power supply to a single cable connection.



Medical/Industrial platform



Infineon MD8710, Bluetooth® enabled single chip medical/industrial platform

The MD8710 is an integrated data acquisition and processing microcontroller for medical and industrial applications. It features a powerful ARM Cortex R4 processor as a main control unit together with a comprehensive CPU subsystems including interrupt control unit, dma controller, watchdog timer and system integrity checker.

The advanced analog frontend of MD8710 combines two main 16 Bit DAC & ADCs for synchronous Stimuli and Response measurements including onchip multi wave stimuli generator & programmable DSP filtering options for the receive part e.g. nyquist filtering.

Further up to four secondary input auxiliary Operational Amplifiers allow observing additional analog signals.

Wireless and wired interconnectivity for data exchange and control is provided by the integrated Bluetooth engine with radio and USB 2.0 OTG interface. Infineon as a member of the Continua Health Alliance provides support for the respective protocols and standards. E.g. BT-Healthprofile is in preparation to be made available together with the build-in System API functions to other access peripherals and interfaces of the device like I²C, SPI, UART, SWI Single Wire Interface. An embedded power management unit is available to generate and monitor all needed voltages from one external voltage source. It can handle different power saving and wakeup scenarios as well as LiIon battery charging, functionality including fuel gauging.

Additionally the MD8710 includes a display controller with basic hardware acceleration functions which supports matrix LCD and OLED displays for portable devices.

Auxiliary PWM units and Outputs can be used e.g. for backlight control or serve other D/A conversion needs for e.g. heating, motor or pump controls.

The overall low power design together with scalable system performance accessible via an eARM Cortex R4 together with the ability to integrate advanced analytic functions and transfer those results instantly via a wireless Bluetooth interface makes this a unique device for medical and industrial applications seeking lowest system implementation costs with high flexibility.

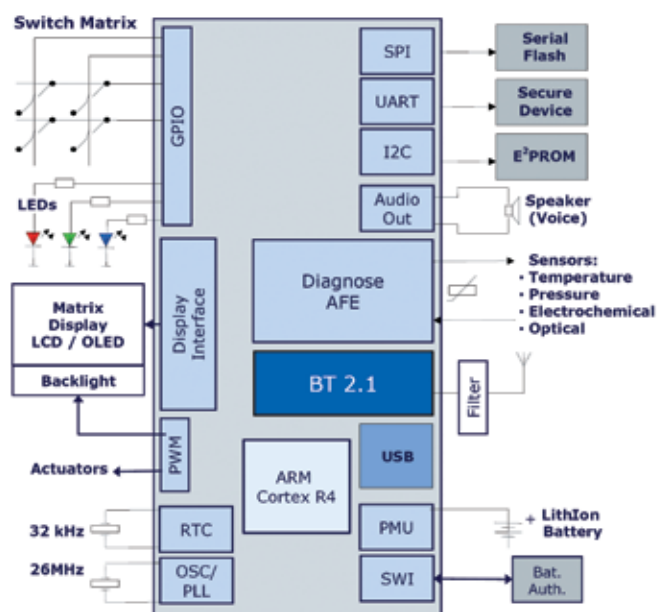



Stub, swivel and whip antennas

Adhesive antenna

Antennas

Hole mounted antennas

Order number	Description
WIREAC1026	GSM 900/1800 MHz, 3m cable, SMA/m
WIREAC1322	GSM 850/900/1800/1900/2100 MHz, 3m cable, SMA/m
WIREAC1071	GSM 900/1800 MHz, 2m cable, FME/m
WIREAC1383	GPS 1575,42 MHz, 5m cable, SMA/m
WIREAC1360	ISM 868 MHz, 50 cm cable, SMA/m
WIREAC1154	Bluetooth/Wlan 2-4 GHz 1.4m cable, SMA/m
WIREAC1427	Bluetooth/Wlan 2.4 GHz 1.0m cable, SMA/m
WIREAC1266	Bluetooth/Wlan 2.4 GHz 2.5m cable, RP SMA
WIREAC1120	GPS/GSM 900/1800MHz, 3m cable, Fakra/C (GPS) & Fakra/D (GSM)
WIREAC1100	GPS/GSM 900/1800MHz, 3m cable, SMA/M (GPS) & FME/F (GSM)
WIREAC1139	GPS/GSM 900/1800MHz, 5m cable, SMA/M (GPS) & FME/F (GSM)
WIREAC1210	GPS/GSM 850/900/1800/1900/2100 MHz, 5m cable, SMA/M (GPS) & FME/F (GSM)
WIREAC1211	GPS/GSM 850/900/1800/1900/2100 MHz, 5m cable, SMA/M (GPS) & SMA/M (GSM)
WIREAC1386	GPS/WLAN, 1575,42 MHz & 2,4 GHz 3m cable, SMA/M (GPS) & SMA/M (WLAN)

Adhesive antennas

Order number	Description
WIREAC1062	GSM, T-shape, 900/1800 MHz, 3m cable, MMCX/m R/A
WIREAC1080	GSM, T-shape, 900/1800 MHz, 3m cable, FME/f
WIREAC1081	GSM, I-shape, 900/1800 MHz, 3m cable, FME/f
WIREAC1027	GSM, T-shape, 900/1800 MHz, 3m cable, SMA/m
WIREAC1028	GSM, I-shape, 900/1800 MHz, 3m cable, SMA/f
WIREAC1130	GSM, O-shape, 850/900/1800/1900MHz, 2.5m cable, FME/f
WIREAC1294	Bluetooth/Wlan , 2.4 GHz, 1m cable, SMA/m
WIREAC1050	GPS/GSM 900/1800MHz, 3m cable, SMA/M (GPS) & FME/F (GSM)
WIREAC1173	GPS/GSM 900/1800MHz, 5m cable, SMA/M (GPS) & FME/F (GSM)
WIREAC1186	GPS/GSM 900/1800MHz, 3m cable, SMA/M (GPS) & SMA/M (GSM)
WIREAC1118	GPS/GSM 850/900/1800/1900/2100 MHz, 3m cable, SMA/m (GPS), FME/f (GSM)

Stub, whip and swivel antennas

Order number	Description
WIREAC1093	Stub antenna, 900/1800 MHz, FME/f
WIREAC1094	Stub antenna, 900/1800 MHz, FME/f R/A
WIREAC1366	Stub antenna, 850/900/1800/1900/2100 MHz, FME/f
WIREAC1249	Stub antenna, 850/900/1800/1900/2100 MHz, FME/f R/A
WIREAC1031	Stub antenna, 850/900/1800/1900 MHz, SMA/m
WIREAC1032	Stub antenna, 900/1800/1800/1900 MHz, SMA/m R/A
WIREAC1303	Stub antenna, 850/900/1800/1900/2100 MHz SMA/m
WIREAC1302	Stub antenna, 900/1800/1800/1900/2100 MHz SMA/m R/A
WIREAC1275	Stub antenna 433 MHz SMA/m
WIREAC1229	Stub antenna 433 MHz SMA/m R/A
WIREAC1276	Stub antenna 868 MHz SMA/m
WIREAC1230	Stub antenna 868 MHz SMA/m R/A
WIREAC1044	Swivel antenna, 900/1800 MHz, FME/f
WIREAC1035	Swivel antenna, 900/1800 MHz, SMA/m
WIREAC1267	Swivel antenna 868MHz SMA/m
WIREAC1007	Whip antenna, 900/1800 MHz, 1/2 wave, FME/f
WIREAC1131	Stub antenna, 2.4 GHz, SMA/m
WIREAC1076	Swivel antenna, 2.4 GHz, SMA/m
WIREAC1181	Swivel antenna, 2.4 GHz, RP SMA

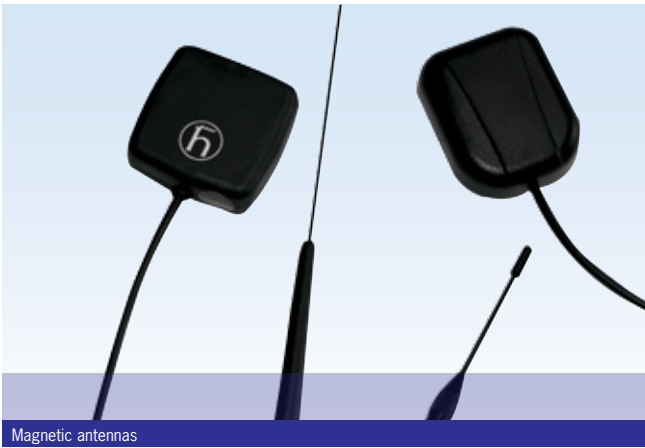

Magnetic antennas



Adhesive antenna

Antennas

Magnetic antennas

Order number	Description
WIREAC1043	GSM 900/1800 MHz, 3m cable, FME/f
WIREAC1295	GSM 850/900/1800/1900/2100 MHz, 2.5m cable, FME/f
WIREAC1045	GSM 900/1800 MHz, 3m cable, MMCX/m R/A
WIREAC1029	GSM 900/1800 MHz, 3m cable, SMA/m
WIREAC1292	GSM 850/900/1800/1900/2100 MHz, 2.5m cable, SMA/m
WIREAC1092	GPS, 1.5m cable BNC
WIREAC1063	GPS, 5m cable, BNC
WIREAC1117	GPS, 3m cable, Fakra
WIREAC1143	GPS, 3m cable, MMCX/m
WIREAC1237	GPS, 2.5m cable SMA/m
WIREAC1116	GPS, 3m cable SMA/m
WIREAC1025	GPS, 5m cable, SMA/m

Surface mounted antennas

Order number	Description
WIREAC1270	Ceramic GSM 900/1800 MHz
WIREAC1304	Ceramic ISM 434MHz
WIREAC1335	Ceramic ISM 868 MHz
WIREAC1409	Ceramic 1.575 GHz
WIREAC1269	Ceramic Bluetooth/Wlan 2.45 GHz
WIREAC1437	GPS Patch 12x12x4 mm
WIREAC1404	GPS Patch 15x15x4 mm

There are more antennas available, please let us know your demand and we will be able to support you.

Internal antennas

Order number	Description
WIREAC1203	GSM 900/1800/1900 MHz, 10 cm cable, GSC
WIREAC1204	GSM 900/1800/1900 MHz, 10 cm cable, U.FL
WIREAC1205	GSM 900/1800/1900 MHz, 10 cm cable, MMCX/m R/A
WIREAC1206	GSM 850/900/1800/1900/2100 MHz, 10 cm cable, GSC
WIREAC1207	GSM 850/900/1800/1900/2100 MHz, 10 cm cable, U.FL
WIREAC1208	GSM 850/900/1800/1900/2100 MHz, 10 cm cable, MMCX/m R/A
WIREAC1278	GPS 1575.42 MHz, 7cm cable, MMCX/m R/A
WIREAC1435	GPS 1575.42 MHz, 10 cm cable, MMCX/m R/A
WIREAC1222	GPS 1575.42 MHz, 10 cm cable, U.FL
WIREAC1284	Wlan 2.4/5.2 GHz, 10 cm cable, U.FL



WIREAC1050

WIREAC1120



Adhesive antenna WIREAC1080



WIREAC1210



WIREAC1155



Flip SIM holder

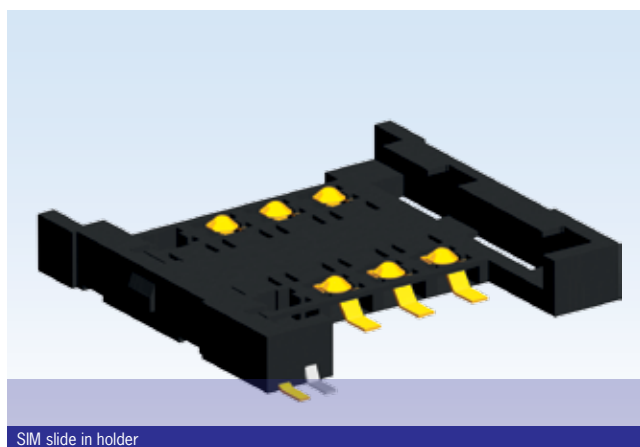

SIM slide in holder

Adapter cables

Order number	Description
WIREAC1099	GSC to FME/m (BH) 10CM
WIREAC1182	GSC to SMA/f (BH) 10CM
WIREAC1183	GSC to SMA/f (BH) 15CM
WIREAC1184	GSC to SMA/f (BH) 20CM
WIREAC1146	GSC to open end 20MM
WIREAC1046	MMCX/m R/A to FME/m (BH) 10CM
WIREAC1047	MMCX/m R/A to FME/m (BH) 15CM
WIREAC1083	MMCX/m R/A to FME/m (BH) 20CM
WIREAC1033	MMCX/m R/A to SMA/f (BH) 10CM
WIREAC1109	MMCX/m R/A to SMA/f (BH) 15CM
WIREAC1036	MMCX/m R/A to SMA/f (BH) 18CM
WIREAC1051	MMCX/m R/A to SMA/f (BH) 20CM
WIREAC1156	U.FL (Ipx) to Fakra C (BH) 20CM
WIREAC1157	U.FL (Ipx) to Fakra D (BH) 20CM
WIREAC1082	U.FL (Ipx) to FME/m (BH) 15CM (1.13mm)
WIREAC1179	U.FL (Ipx) to FME/m (BH) 15CM (1.37mm)
WIREAC1113	U.FL (Ipx) to FME/m (BH) 17.5CM
WIREAC1037	U.FL (Ipx) to SMA/f (BH) 10CM
WIREAC1112	U.FL (Ipx) to SMA/f (BH) 15CM
WIREAC1055	U.FL (Ipx) to SMA/f (BH) 20CM
WIREAC1101	U.FL (Ipx) to SMA/f PCB 8.5 CM
WIREAC1077	U.FL (Ipx) to RP SMA/(M) (BH) 10CM
WIREAC1034	W.FL to SMA/f (BH) 10CM
WIREAC1163	W.FL to SMA/f PCB 5.5CM

We can offer custom made adapter cables with different type of RF connectors, cable length and cable diameter (type). Please, inform us of your specification.

System connectors

Order number	Description
WIREAC1013	60 PIN (SMT) for GC864-QUAD-C2
WIREAC1014	60 PIN (DIP) for GC864-QUAD-C2
COREC19998	50 PIN (SMT) for GM862-XXX family
COREC21477	80 PIN (SMT) for GC864-QUAD, UC864xx

These system connectors all fit for Telit GSM modules. If you require a system connector for any other type of GSM modules, please let us know and we will support you.

SIM holders

Flip type

Order number	Part number	SIM detection	Location peg
WIREAC1039	CH03-BH060-ABR-L	Yes	No
WIREAC1069	CH03-BH060-AAR-L	Yes	Yes

Slide in type

Order number	Part number	SIM detection	Location peg
WIREAC1134	CH03-AA060-AAR-L	Yes	Yes
WIREAC1192	CH03-AB060-OBR	Yes	No

Push/Push type

Order number	Part number	SIM detection	Location peg
WIREAC1369	CH03-DC060-ABR	Yes	No
WIREAC1380	CH03-DC060-AAR	Yes	Yes

The logo for webg@te features the text 'webg@te' in a white, sans-serif font. The '@' symbol is replaced by a stylized globe with latitude and longitude lines, set against a blue background with abstract light patterns.

www.rutronik.com/webgate

RUTRONIK Webg@te – stock around the clock.

Online Catalogue

The Online Catalogue gives you an overview of all products – including prices, inventory levels and detailed data sheets.

Search function based on technical parameters

The customer defines all relevant parameters and thereby limits the product search. A specific selection is always achieved as a result.

Product Consultant

The electronic Product Consultant “watches” in the background. It provides current recommendations on interesting and reasonably priced articles. This makes the product specialists’ know-how available to you around the clock.

Sample ordering

The newly integrated option for ordering samples helps our customers to drive forward their development processes quickly. We work closely with manufacturers, ensuring that the customer receives the components at short notice.

Procurement

The customer can see his orders, contracts, articles and inventory levels in Procurement.

- All orders can be followed online via the Tracking System.
- Information includes the order numbers and status, requested and delivery dates. New delivery dates can be agreed upon online.
- The contract overview quickly presents the status of all contracts.
- A list of all articles ordered by the customer in the past completes the Procurement module.

Product Change Notifications

The Product Change Notifications (PCNs) Database includes all product changes, withdrawals and original reports from the manufacturers.

- Interacting closely with the Online Catalogue, the user already receives information on existing PCNs when searching for the articles.
- In this case, the Product Consultant quickly offers an equivalent replacement.
- The PCNs database supports you with product planning and provides up-to-date information, which is especially important with the RoHS Directive.

Webg@te

The more intelligent form of eBusiness

Rutronik Webg@te is a modular eCommerce platform. It consists of an Online Catalogue, a Product Change Notifications (PCNs) Database and Procurement. Webg@te delivers information around the clock in real time, takes orders and issues status information. **Added value** The complete Rutronik product range is available in Webg@te for online ordering: semiconductors, passive and electromechanical components, storage technologies, displays & embedded boards as well as wireless technologies. The order option for component samples is brand new. **Always the right thing** Rutronik Customer Service always offers the right “fit”. Webg@te does not replace personal service but flexibly complements local customer service to meet customer wishes and requirements. **Borderless in practice** Webg@te is just as European as Rutronik. Online customers can rely upon the same business and delivery conditions throughout Europe.

Austria

RUTRONIK Elektronische Bauelemente Ges. m. b. H.
Durisolstraße 1
4600 Wels
Tel. +43 7242 44901
Fax +43 7242 44901-33

Belgium

RUTRONIK Elektronische Bauelemente GmbH
Keppekouter 1
Ninovesteenweg 198
9320 Erembodegem-Aalst
Tel. +32 53 606590
Fax +32 53 77 1262

Bulgaria

RUTRONIK Elektronische Bauelemente GmbH
Zheko Voyvoda street no. 5
1756 Sofia
Tel. +359 2 97486-46
Fax +359 2 97486-45

Czech Republic

RUTRONIK Elektronische Bauelemente CZ s.r.o.
Brno
Slavičkova 1a, 63800 Brno
Tel. +420 5 45424-681
Fax +420 5 45424-670
Prague
Papirenská 1, 160 00 Praha
Tel. +420 2 33343120
Fax +420 2 33323955

Denmark

RUTRONIK Elektronische Bauelemente GmbH
Herstedøstervej 27-29
2620 Albertslund
Tel. +45 7020 1963
Fax +45 7020 1973

Estonia

RUTRONIK Elektronische Bauelemente GmbH
Vaksali 17A, 50410 Tartu
Tel. +372 6609360
Fax +372 6609362

Germany – Headquarters

RUTRONIK Elektronische Bauelemente GmbH
Industriestraße 2 | 75228 Ispingen/Pforzheim
Tel. +49 (0) 7231 801-0 | Fax +49 (0) 7231 82282 | E-Mail: rutronik@rutronik.com | www.rutronik.com

Berlin

Justus-von-Liebig-Straße 7
12489 Berlin
Tel. +49 30 8092716-0
Fax +49 30 8092716-16

Dortmund

Zum Lonnenhohl 40
44319 Dortmund
Tel. +49 231 95036-0
Fax +49 231 95036-31

Dresden

Radeburger Straße 172
01109 Dresden
Tel. +49 351 205330-0
Fax +49 351 205330-10

Finland

RUTRONIK Elektronische Bauelemente GmbH
Kirkonkyläntie 3
00700 Helsinki
Tel. +358 9 32912200
Fax +358 9 32912222

France

RUTRONIK S.A.S
6, Mail de l'Europe
78170 La Celle St Cloud
Tel. +33 1 30083300
Fax +33 1 30822063
rutronik_sas@rutronik.com

Bordeaux

Tel. +33 5 57264000

Grenoble

Tel. +33 4 76610090

Le Mans

Tel. +33 2 43781697

Lyon

Tel. +33 4 72768000

Poitiers

Tel. +33 5 49528888

Rennes

Tel. +33 2 23451440

Strasbourg

Tel. +33 3 88781212

Hungary

RUTRONIK Magyarország Kft.
Fehérvári út 89-95
1119 Budapest
Tel. +36 1 3710666
Fax +36 1 3710667

Italy

RUTRONIK Italia S.r.l.
21, Via Caldera
Centro Direzionale S.Siro
20153 Milano (MI)
Tel. +39 02 40951-1
Fax +39 02 40951-224
italia_MI@rutronik.com
Ancona
Via 1° Maggio, 150/B
60131 Ancona (AN)
Tel. +39 071 2916218
Bologna
Via Gazzani, 8/2 - Z.I. Bargellino
40012 Calderara di Reno (BO)
Tel. +39 051 6463200
Florence
Via V. Emanuele, 33
50041 Calenzano (FI)
Tel. +39 055 8827332

Naples

Via Arcora, 110, Palazzo Gecos
80013 Casalnuovo di Napoli (NA)
Tel. +39 081 5228709

Padua

Via Savelli, 62
35129 Padova (PD)
Tel. +39 049 8697800

Rome

Via Del Maggolino, 125
00155 Roma (RO)
Tel. +39 06 2287821

Turin

Strada Torino, 43/45
Europalace
10043 Orbassano (TO)
Tel. +39 011 9022000

Lithuania

RUTRONIK Elektronische Bauelemente GmbH
Raudondvario pl.76
47182 Kaunas
Tel. +370 37 261780
Fax +370 37 210363

Norway

RUTRONIK Elektronische Bauelemente GmbH
Olav Helsetts vei 6 · 0694 Oslo
Tel. +47 22 767920
Fax +47 22 767921

Netherlands

RUTRONIK Elektronische Bauelemente GmbH
Papland 4a
4206 CL Gorinchem
Tel. +31 183 6460-50
Fax +31 183 6460-51

Poland

RUTRONIK Polska Sp.z. o.o.
ul. Bojkowska 37
44-101 Gliwice
Tel. +48 32 4612000
Fax +48 32 4612001
Gdynia
ul. Batorego 28-32
81-366 Gdynia
Tel. +48 58 78320-20
Fax +48 58 78320-22
Warsaw
ul. Patriotów 110
04-844 Warszawa
Tel. +48 22 33273-70
Fax +48 22 33273-72

Portugal

RUTRONIK Elektronische Bauelemente GmbH
Avenida Dr. Carlos Bacelar
Edifício Saza Nº 968
Escritório Nº 6-A
4.760-103 V.N.Famalicao
Tel. +351 252 312-336
Fax +351 252 312-338

Romania

RUTRONIK Elektronische Bauelemente GmbH
București
Tel. +40 314 253839
Fax +40 314 253842
Timișoara
Maresal C-tin Prezan 142
300695 Timișoara
Tel. +40 256 401-240
Fax +40 256 401-242

Russia

RUTRONIK
Beteiligungsgesellschaft mbH
Leningradskoje Chaussee 16
Building 3, Office 403
125171 Moscow
Tel. +7 495 7862802
Fax +7 495 7862803

Serbia

RUTRONIK Elektronische Bauelemente GmbH
YUBC Bul. Mihajla Pupina 10z/IV
11070 Beograd
Tel. +381 11 311 3366-3
Fax +381 11 311 3366-4

Slovakia

RUTRONIK Elektronische Bauelemente GmbH, o.z.
Lazovná 11
97401 Banská Bystrica
Tel. +421 48 47223-00
Fax +421 48 47223-08

Slovenia

RUTRONIK Elektronische Bauelemente GmbH
Motnica 5, 1236 Trzin
Tel. +386 1 5610980
Fax +386 1 5610988

Spain

RUTRONIK España S.L.
Barcelona
C/ Marqués de Sentmenat 54 - 58
3º-1º
08029 Barcelona
Tel. +34 93 4442412
Fax +34 93 4442487
Madrid
Ctra. Canillas 138 - 2a Planta - 9B
28043 Madrid
Tel. +34 91 3005528
Fax +34 91 3005328
San Sebastián
Pº Serapio Múgica 8
1ª planta, Of. 8
20016 Donostia-San Sebastián
Tel. +34 943 404528
Fax +34 943 404529

Sweden

RUTRONIK Nordic AB
Kista Science Tower
Färögatan 33 · 16451 Kista
Tel. +46 8 50554900
Fax +46 8 50554950

Switzerland

RUTRONIK Elektronische Bauelemente AG
Volketswil
Hözlwiisenstr. 5 · 8604 Volketswil
Tel. +41 44 9473737
Fax +41 44 9473747
Yverdon-les-Bains
Rue Galilée 15
1400 Yverdon-les-Bains
Tel. +41 24 4239140

Turkey

Partner of RUTRONIK group:
Elektro Elektronik San. Tic. A.Ş.
Burhaniye Mah. Bahceler
Sokak No:10
Beyleybeyi 34676 Uskudar/
Istanbul
Tel. +90 216 5576700
Fax +90 216 5576660

United Kingdom & Ireland

RUTRONIK UK Ltd.
Deakins Business Park,
Blackburn Road, Egerton
BL7 9RP Bolton,
Lancashire
Tel. +44 1204 602200
Fax +44 1204 602210

Berlin

Justus-von-Liebig-Straße 7
12489 Berlin
Tel. +49 30 8092716-0
Fax +49 30 8092716-16

Dortmund

Zum Lonnenhohl 40
44319 Dortmund
Tel. +49 231 95036-0
Fax +49 231 95036-31

Dresden

Radeburger Straße 172
01109 Dresden
Tel. +49 351 205330-0
Fax +49 351 205330-10

Erfurt

Flughafenstraße 4
99092 Erfurt
Tel. +49 361 22836-30
Fax +49 361 22836-31

Frankfurt

Frankfurter Straße 151 c
63303 Dreieich
Tel. +49 6103 27003-0
Fax +49 6103 27003-20

Freiburg

Basler Landstraße 8
79111 Freiburg
Tel. +49 761 611677-0
Fax +49 761 611677-11

Göttingen

Robert-Bosch-Breite 9
37079 Göttingen
Tel. +49 551 634236-60
Fax +49 551 634236-70

Hamburg

Neue Gröningerstraße 10
20457 Hamburg
Tel. +49 40 3596006-20
Fax +49 40 3596006-50

Mannheim

Amselstraße 33
68307 Mannheim
Tel. +49 621 762126-0
Fax +49 621 762126-17

München

Landsberger Straße 478
81241 München
Tel. +49 89 889919-0
Fax +49 89 889919-19

Nürnberg

Südwestpark 10/12
90449 Nürnberg
Tel. +49 911 68868-0
Fax +49 911 68868-90

Ostwestfalen

Brockweg 133
33332 Gütersloh
Tel. +49 5241 23271-0
Fax +49 5241 23271-29

Ratingen

Gothaer Straße 2
40880 Ratingen
Tel. +49 2102 9900-0
Fax +49 2102 9900-19



Photovoltaic Solutions
RUSOL GmbH & Co. KG
Am Bahnhof 5-7
97990 Weikersheim
Tel. +49 7934 9940-0
Fax +49 7934 9940-99
rusol@rusol.com

