

1
Network Communications
David Dietrich
13/767,557
Replacement Sheet

Statement: This substitute specification contains no new matter.

- Remarks:
- Figure 2 is shown whole and is also shown over two pages as Figure 2a and 2b.
 - Figure 42 is shown whole and is also shown over four pages as Figures 42a, 42b, 42c and 42d.
 - All other figures noted in the Notice to File Missing Parts of Nonprovisional Application including but not limited to Figures 3, 18, 21, 22, 25, 27, 38, 40 and 41 have either been expanded or rotated 90 degrees and expanded to increase the font height.
 - Page numbers were added to the top middle of each page.
 - Header of each page includes title, primary inventor, application number and identification that the page is a replacement sheet.

3
Network Communications
David Dietrich
13/767,557
Replacement Sheet



Figure 1

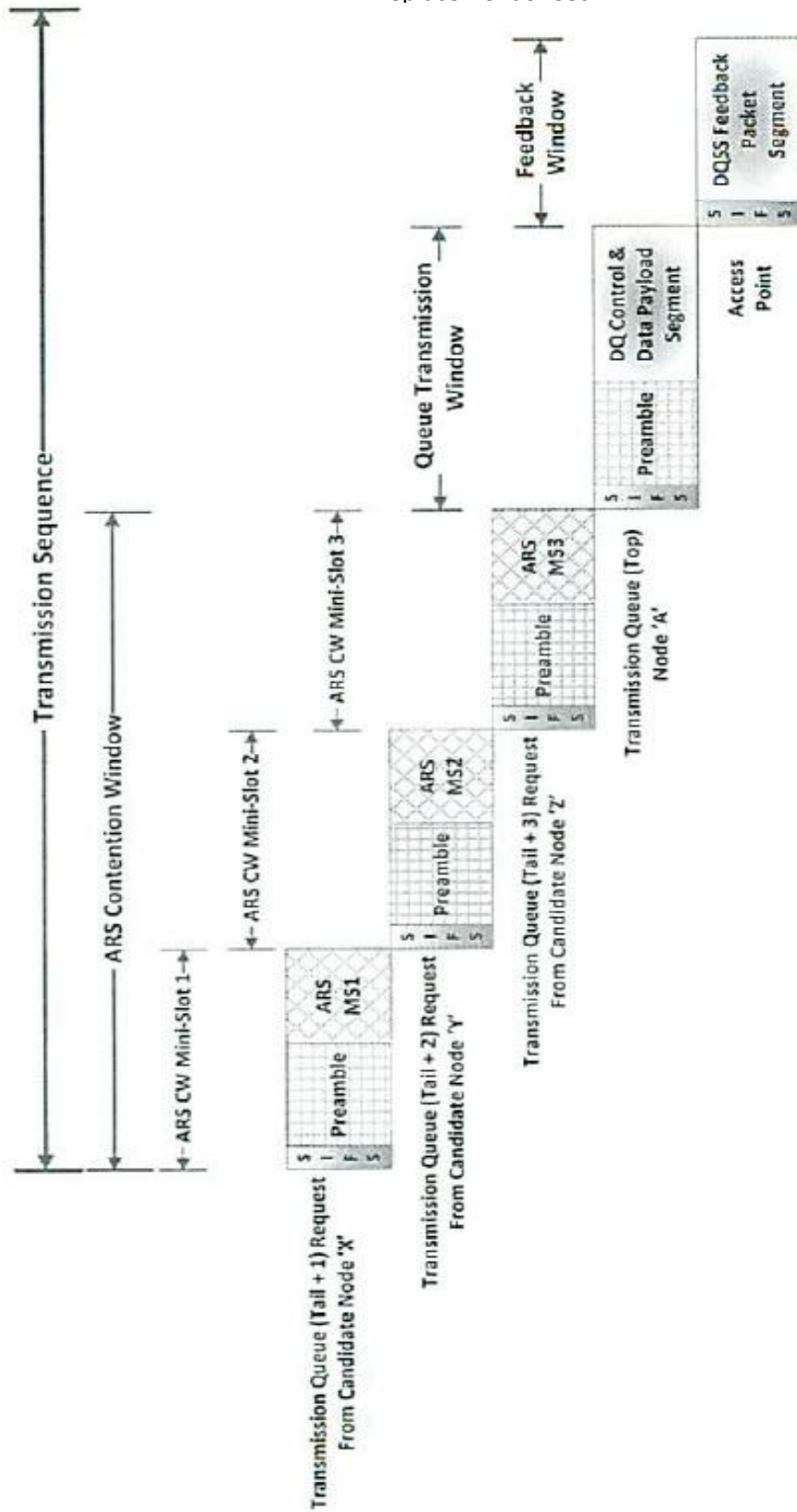

Figure 2

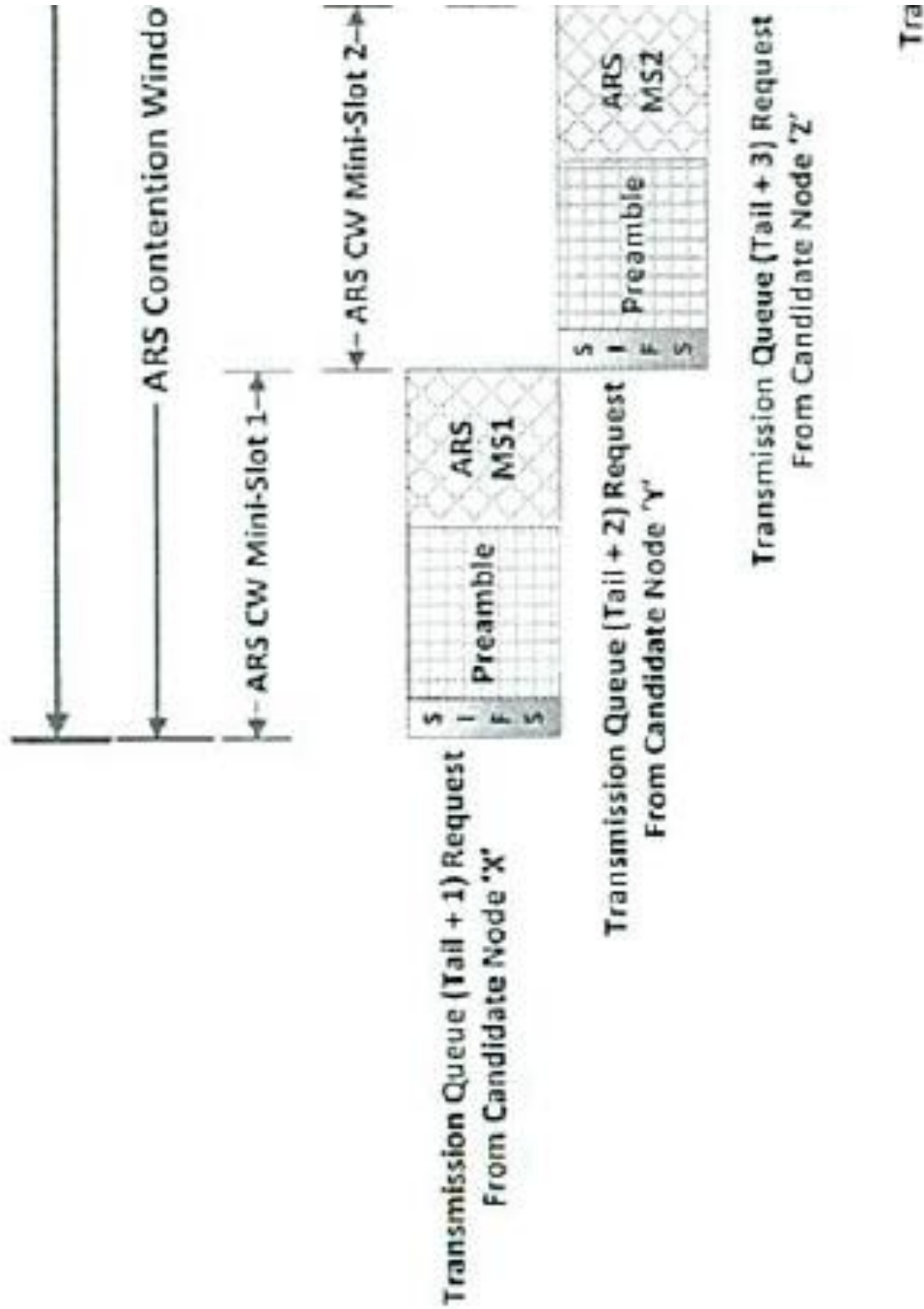

Figure 2a

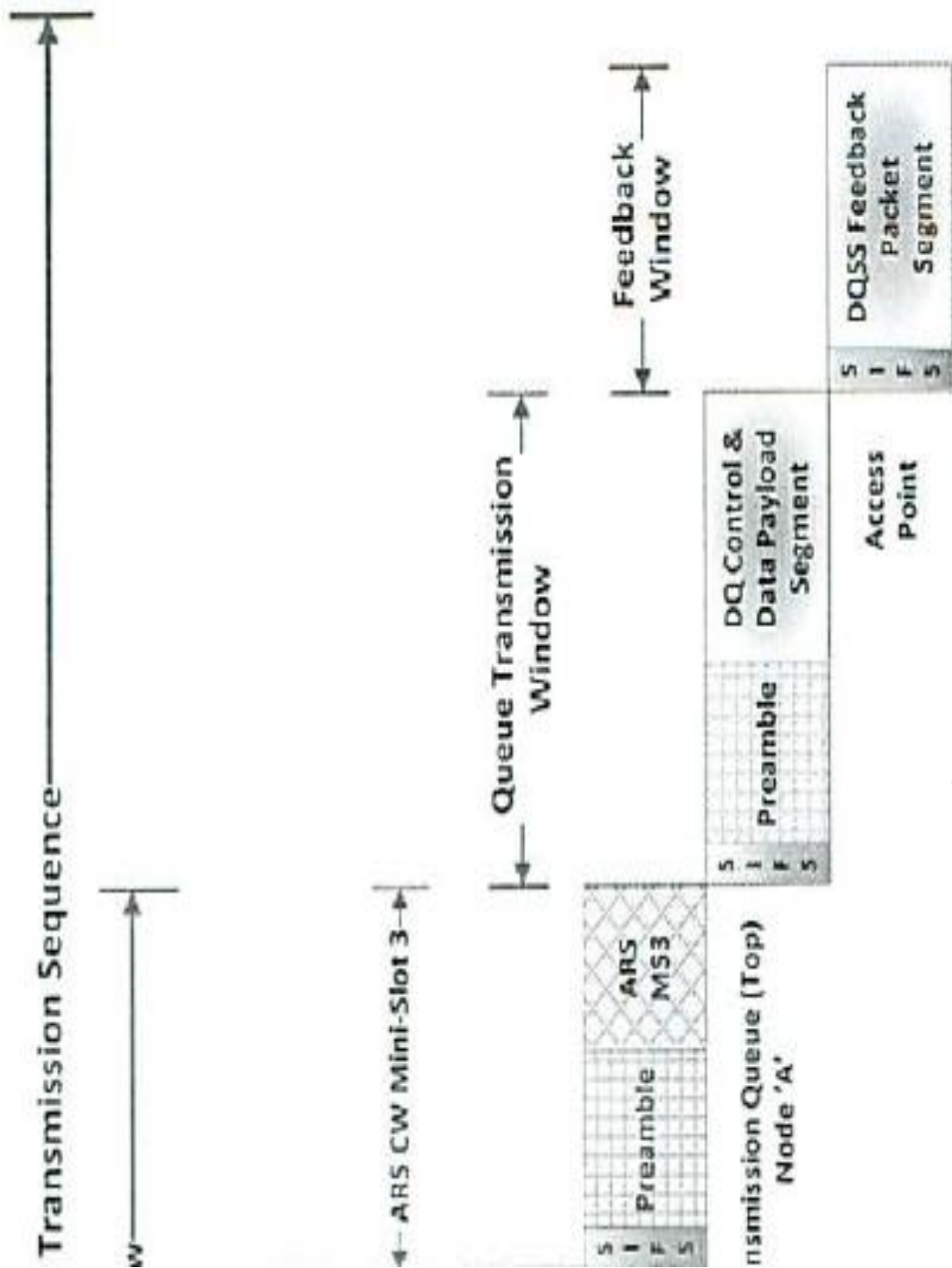

Figure 2b

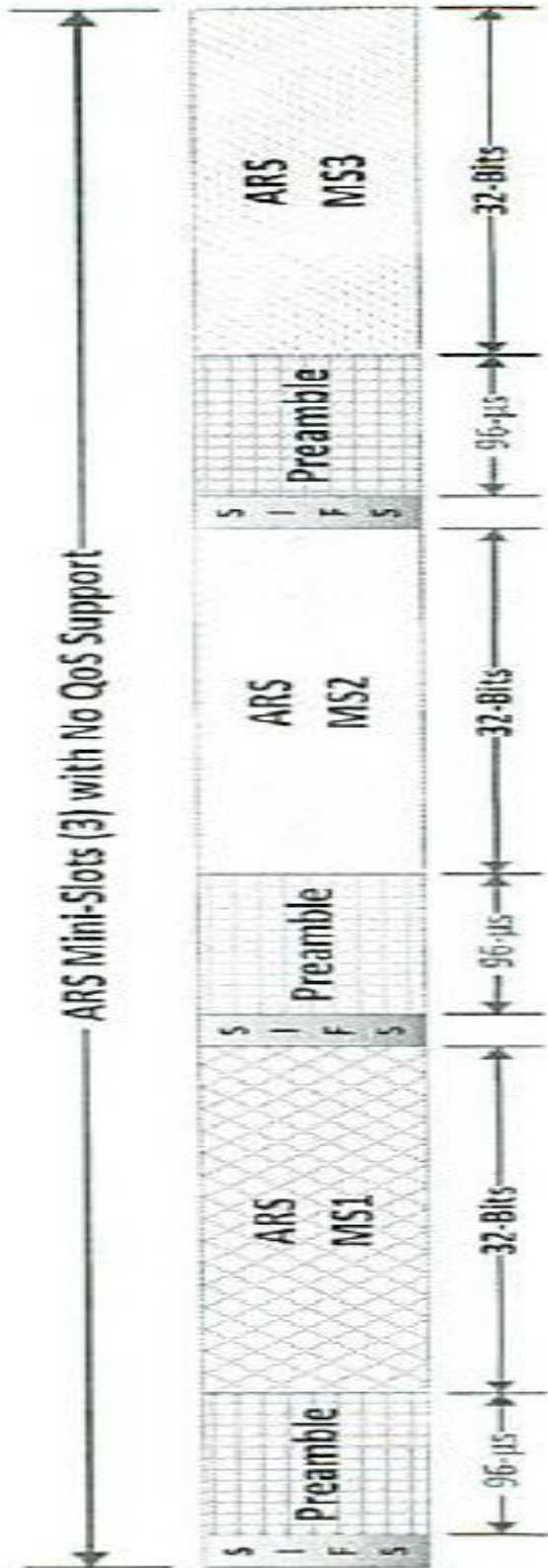

Figure 3

8
 Network Communications
 David Dietrich
 13/767,557
 Replacement Sheet

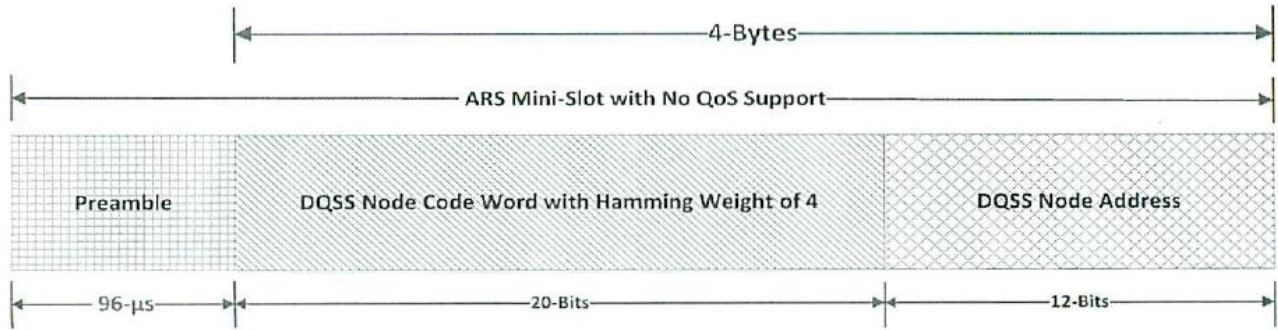

Figure 4

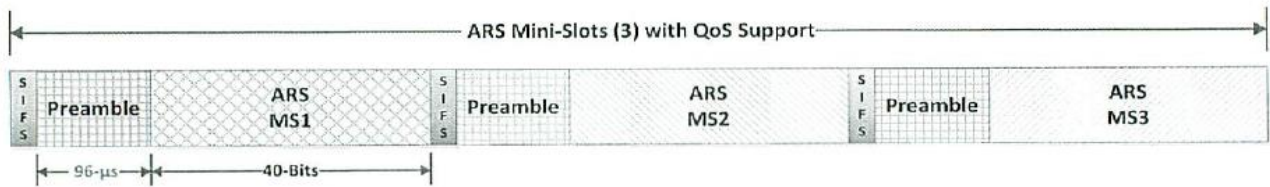

Figure 5

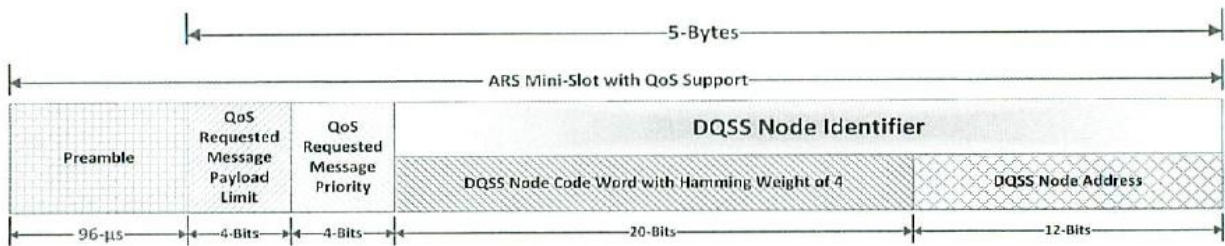

Figure 6

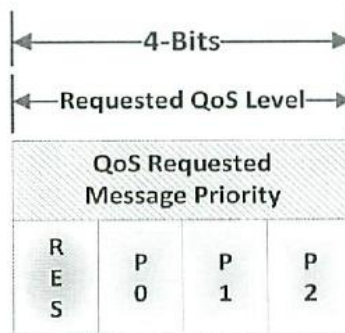

Figure 7

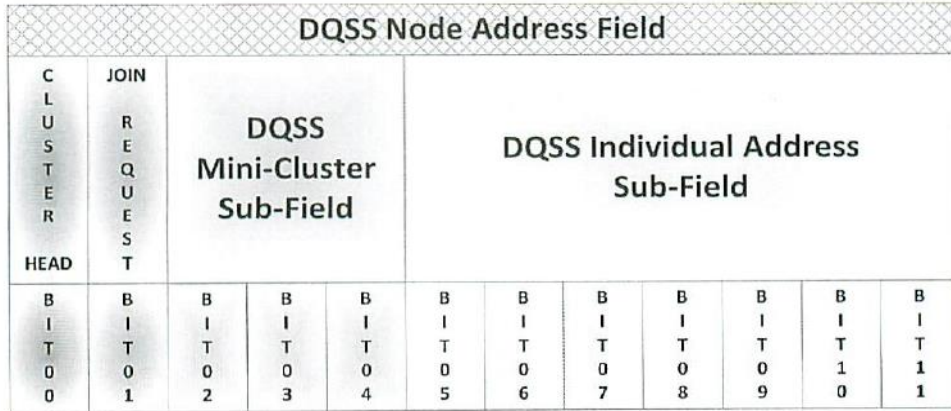

Figure 8

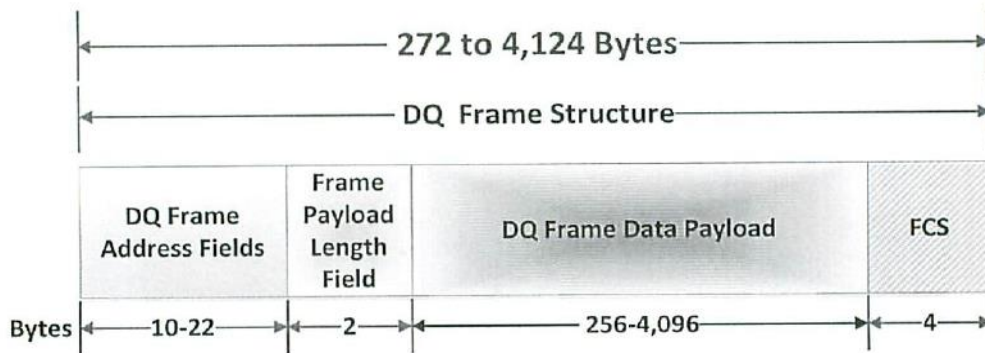

Figure 9

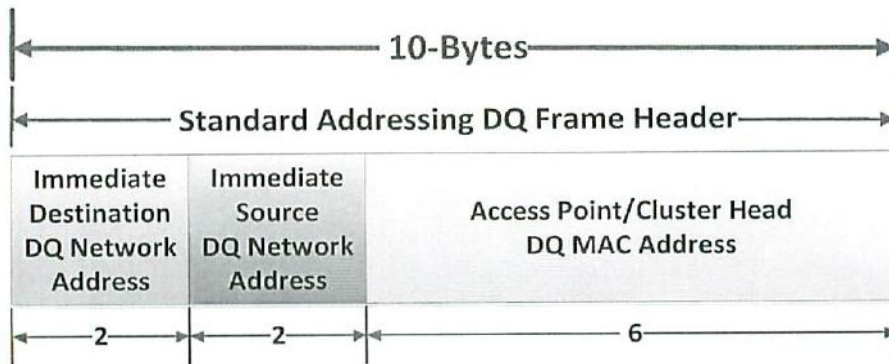

Figure 10

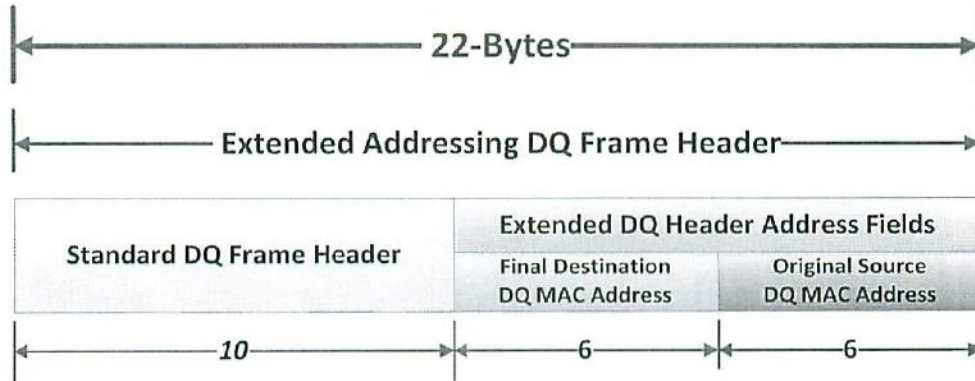

Figure 11

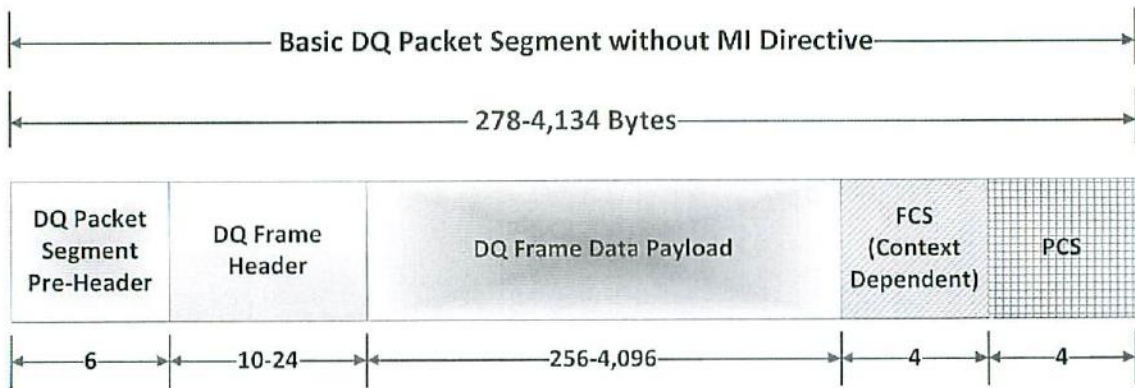

Figure 12

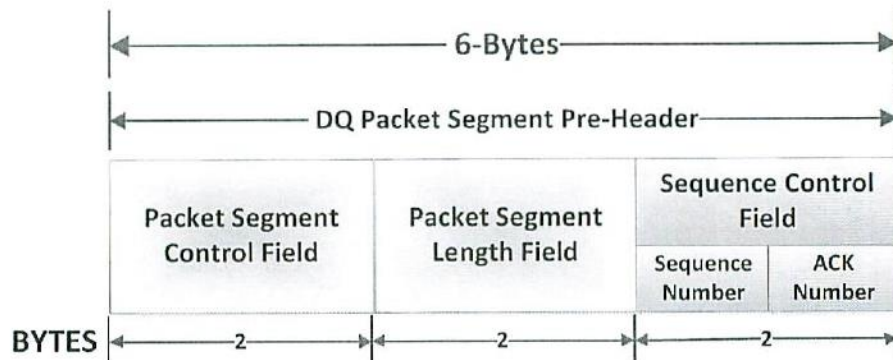

Figure 13

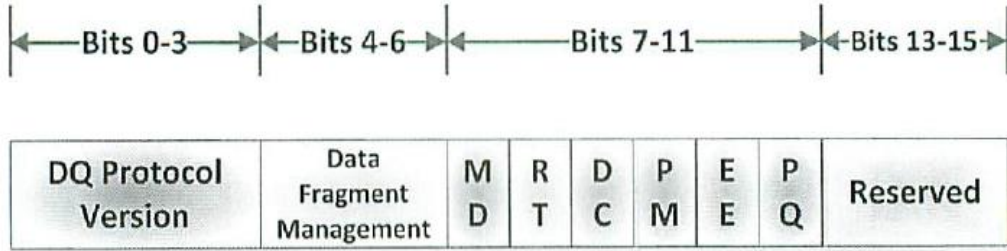

Figure 14

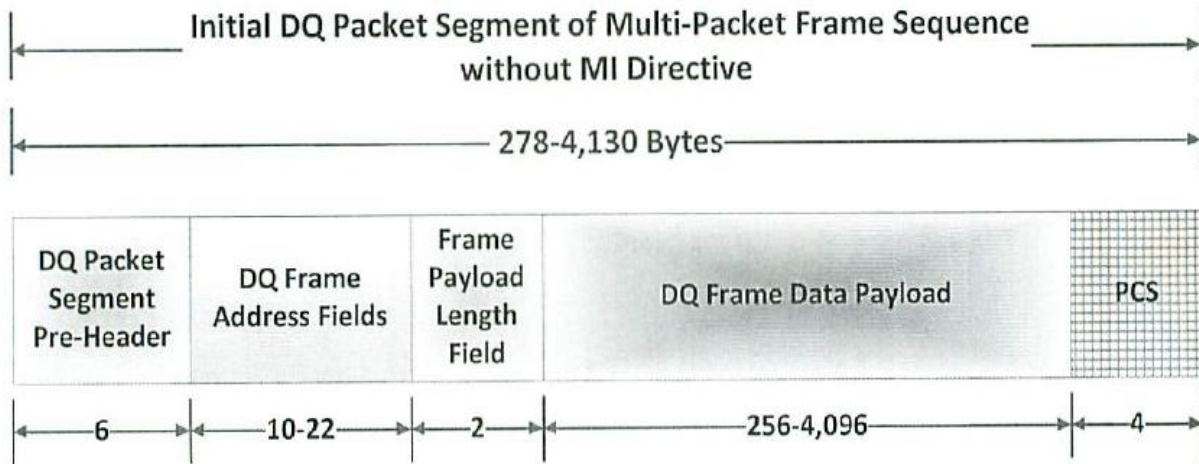

Figure 15

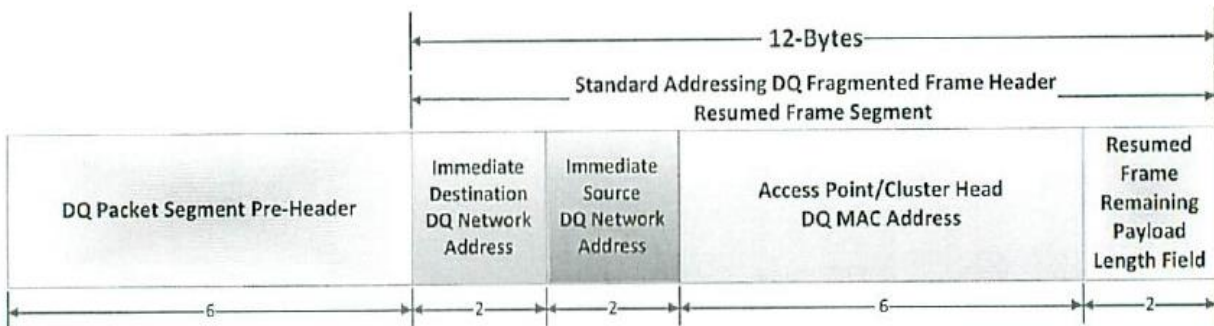

Figure 16

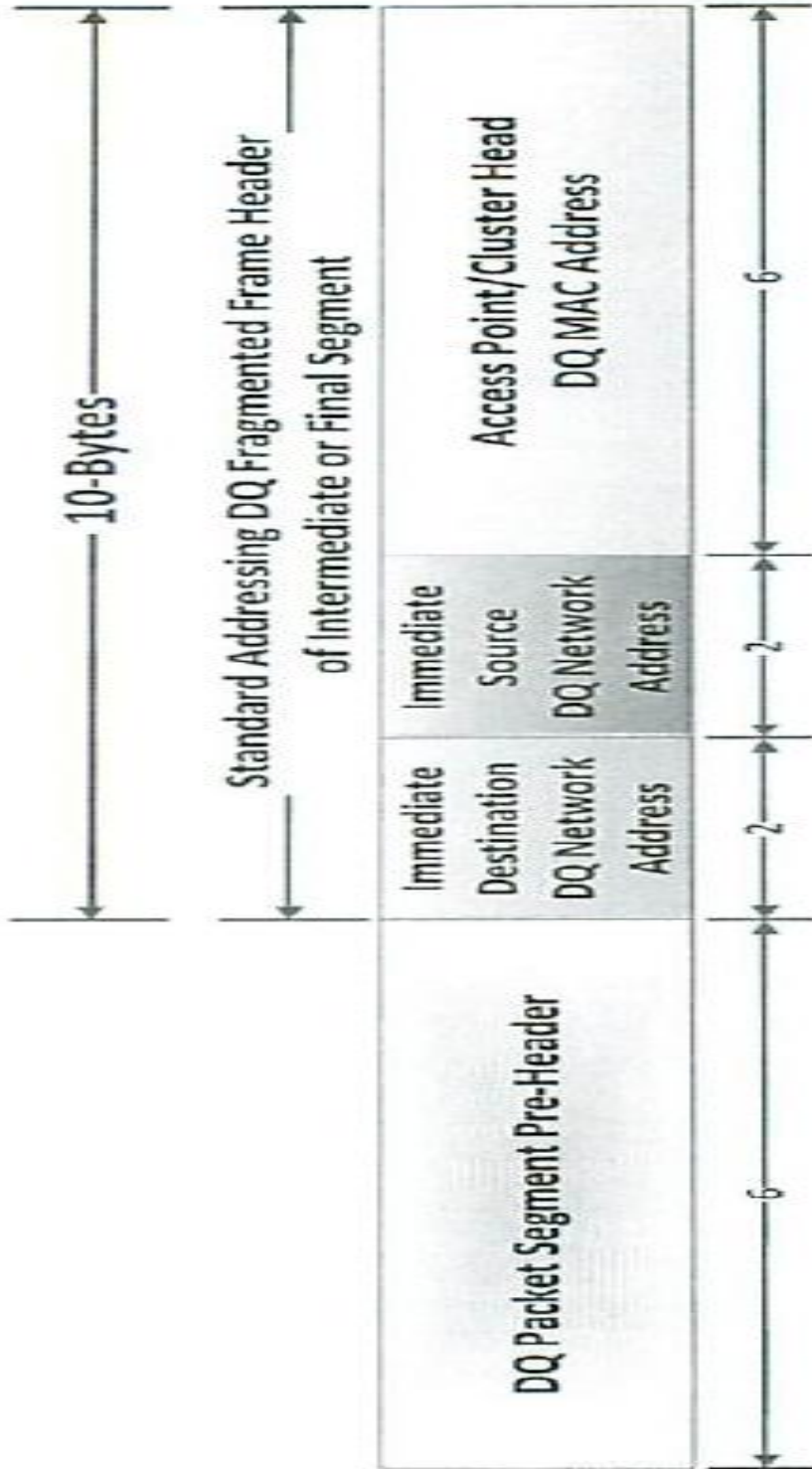

Figure 17

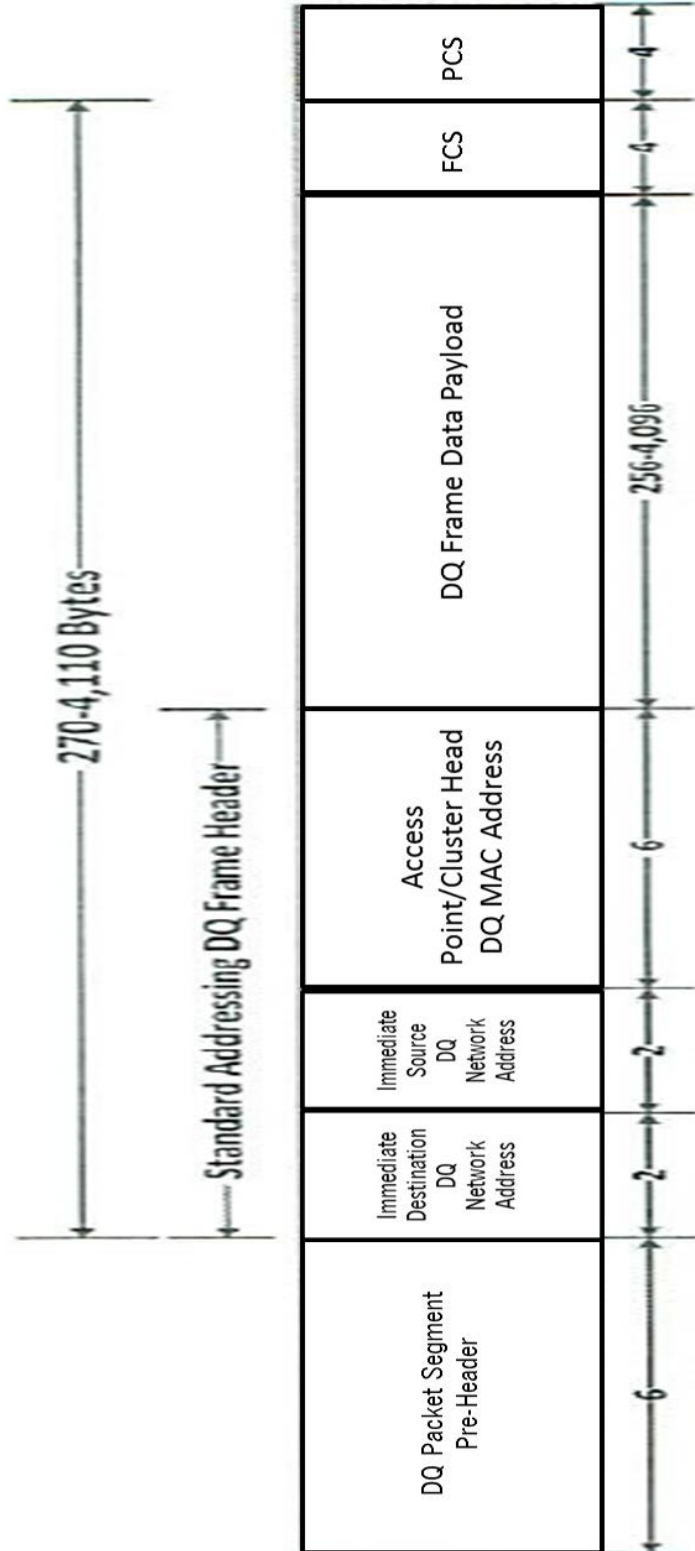

Figure 18

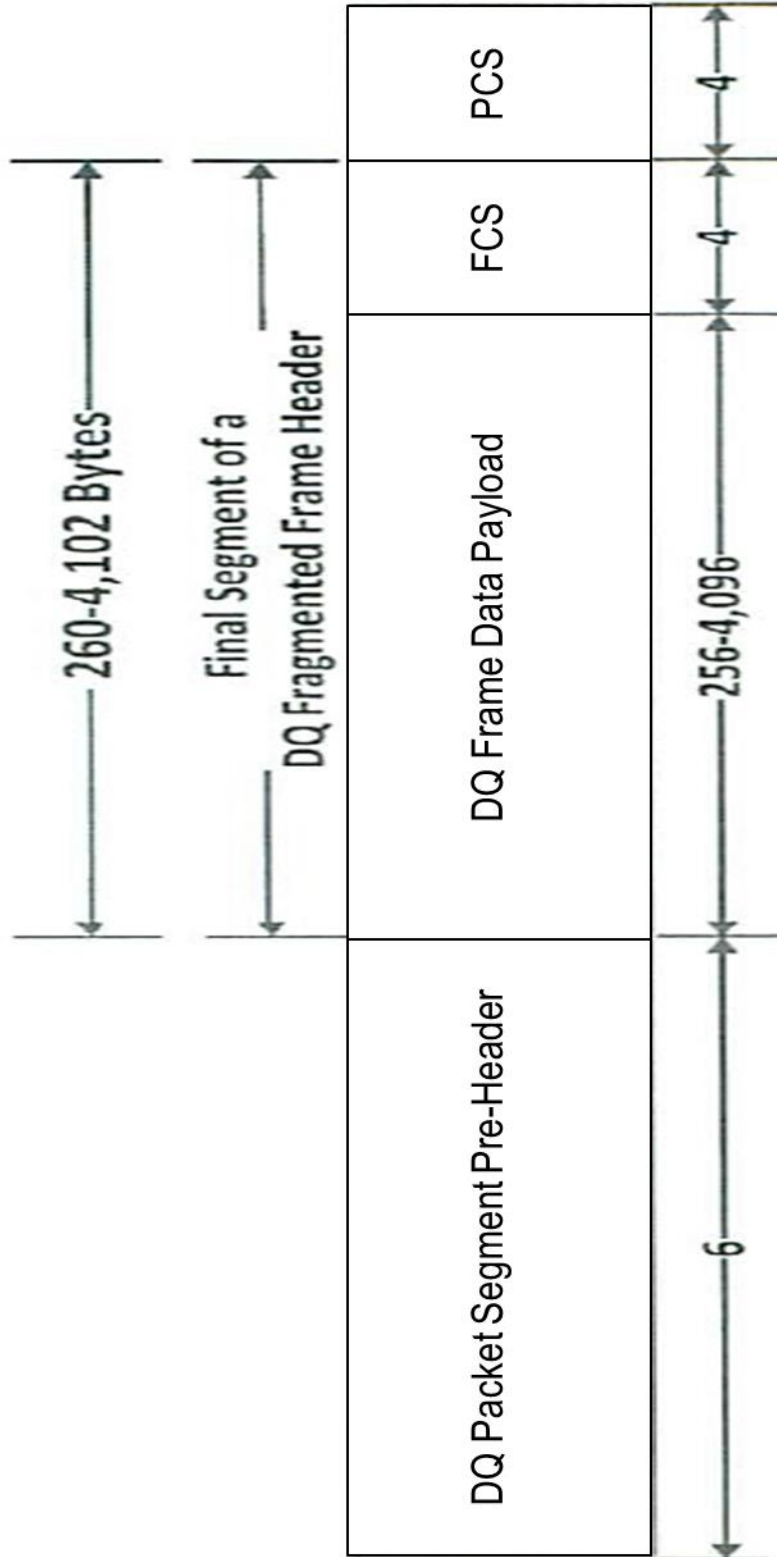

Figure 19

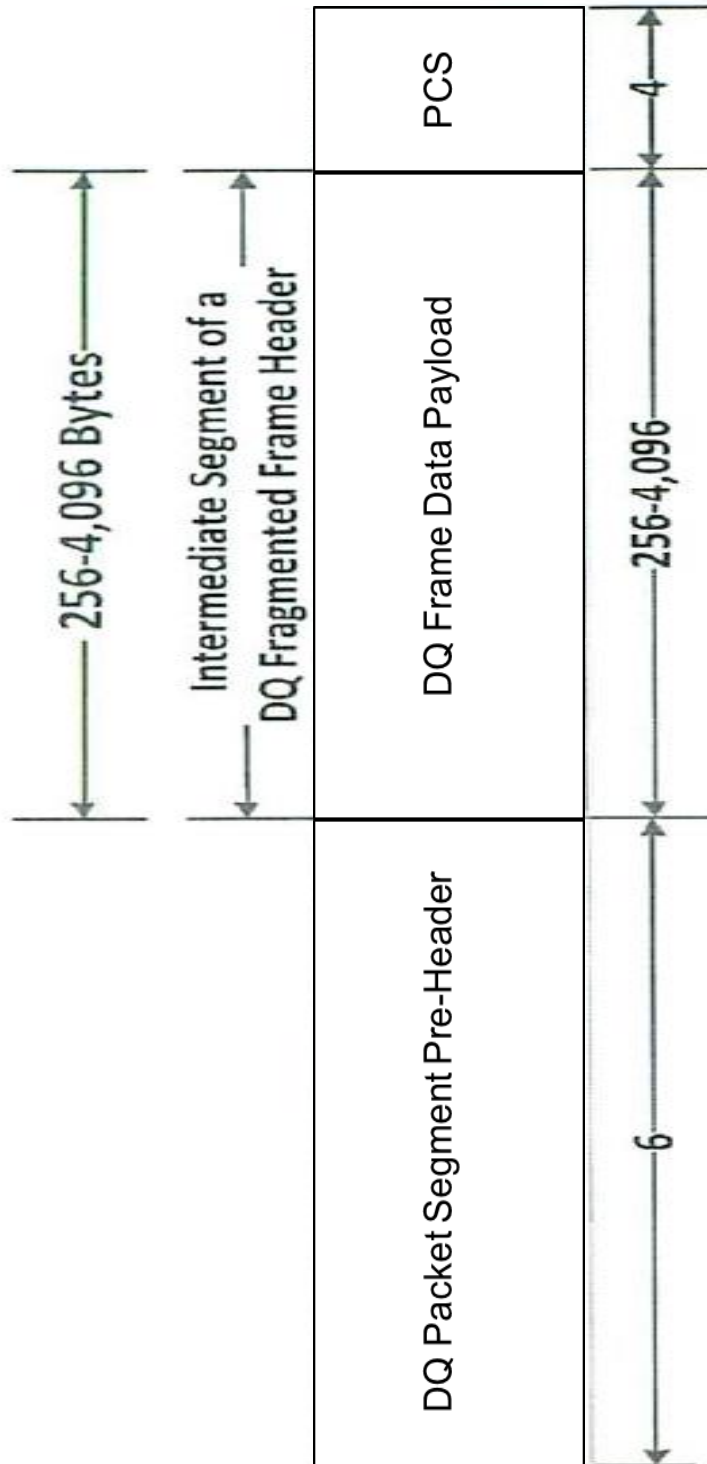

Figure 20

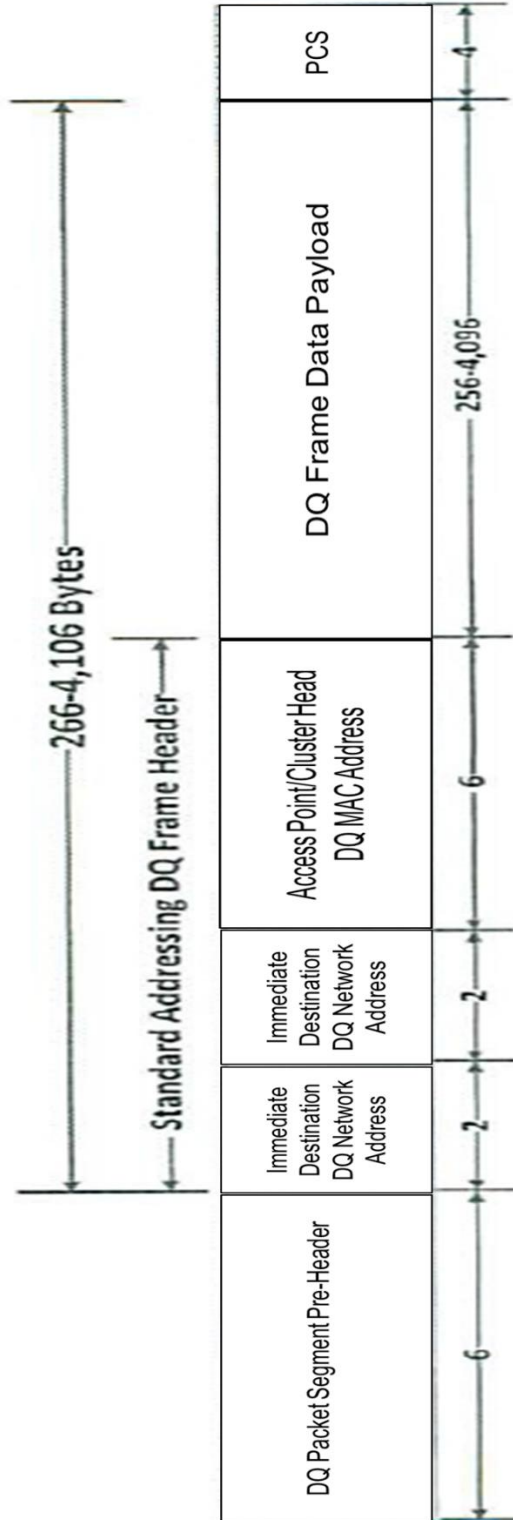

Figure 21

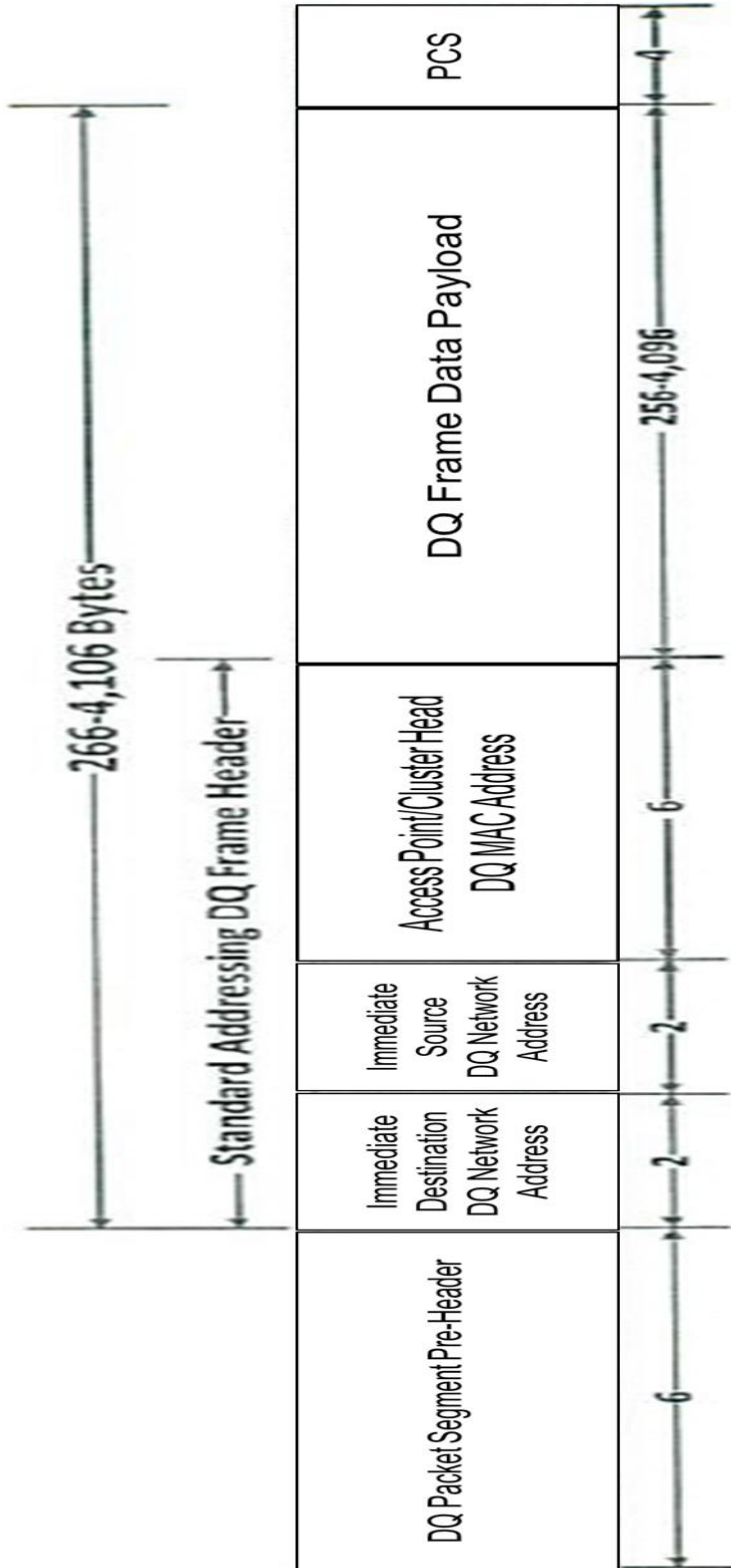

Figure 22

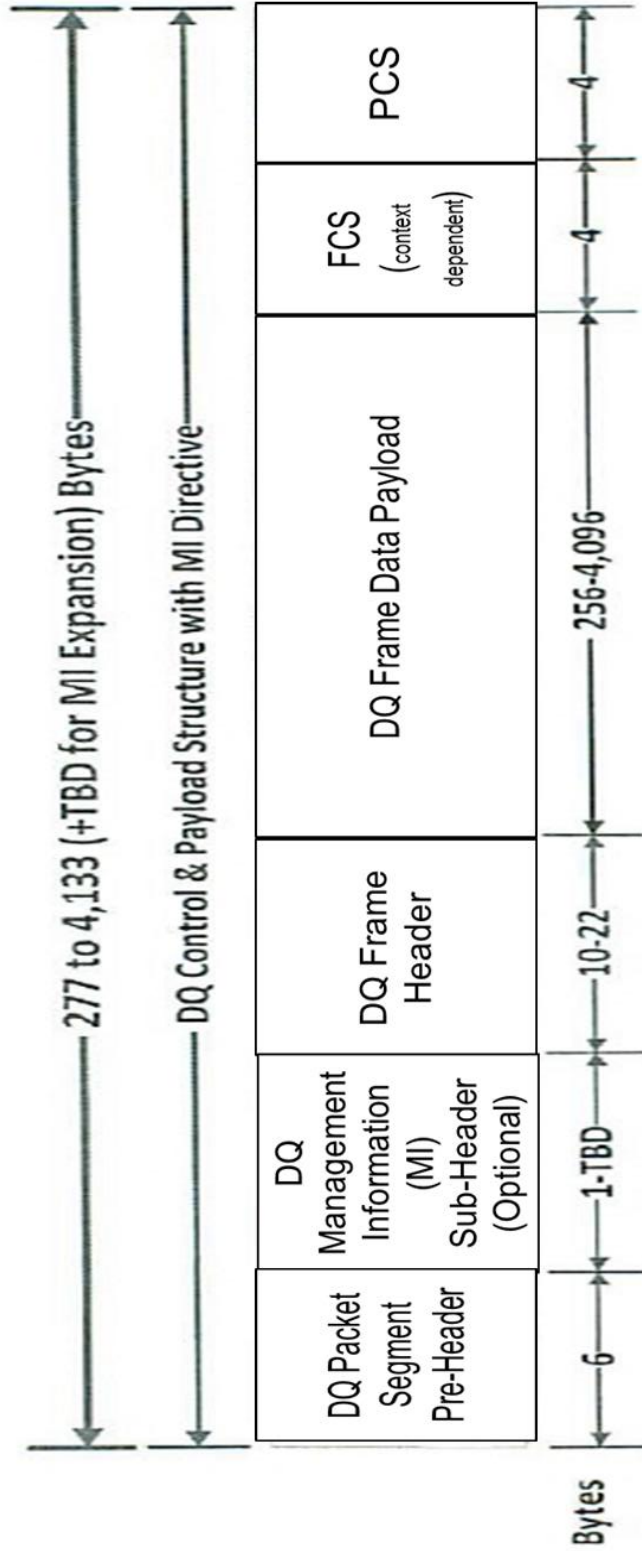

Figure 23

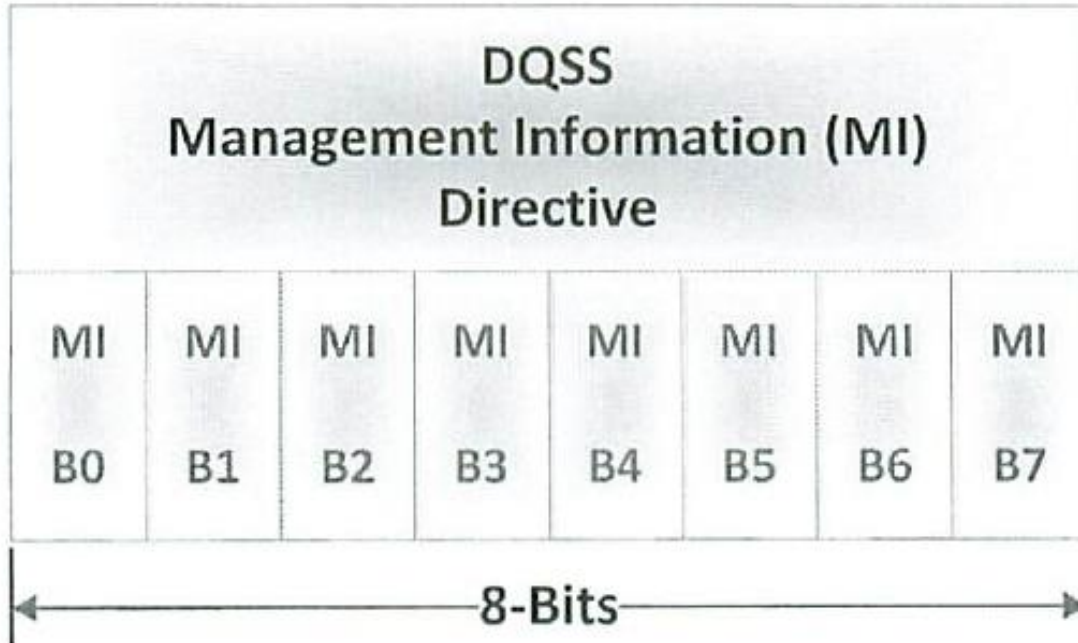

Figure 24

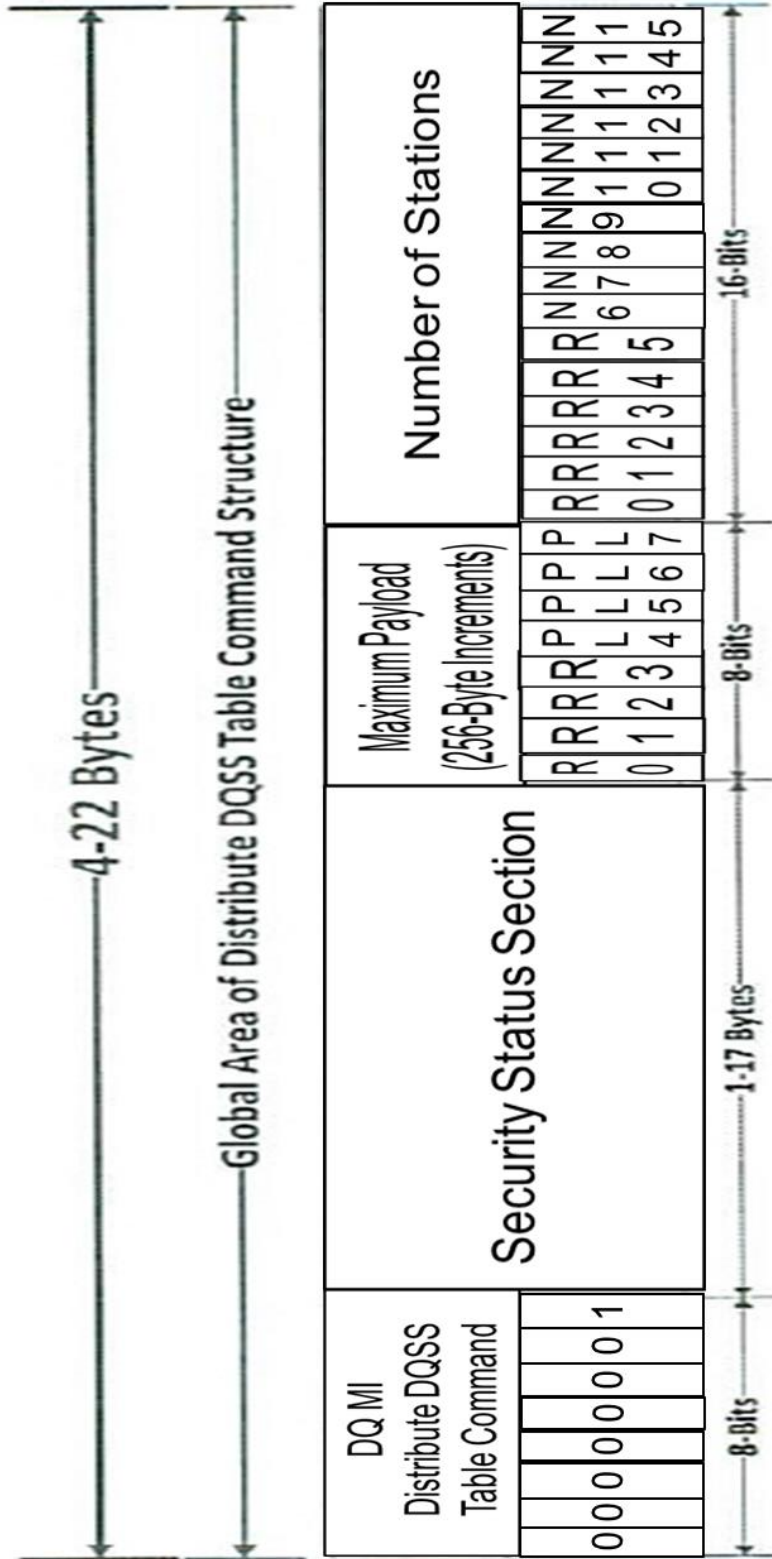

Figure 25

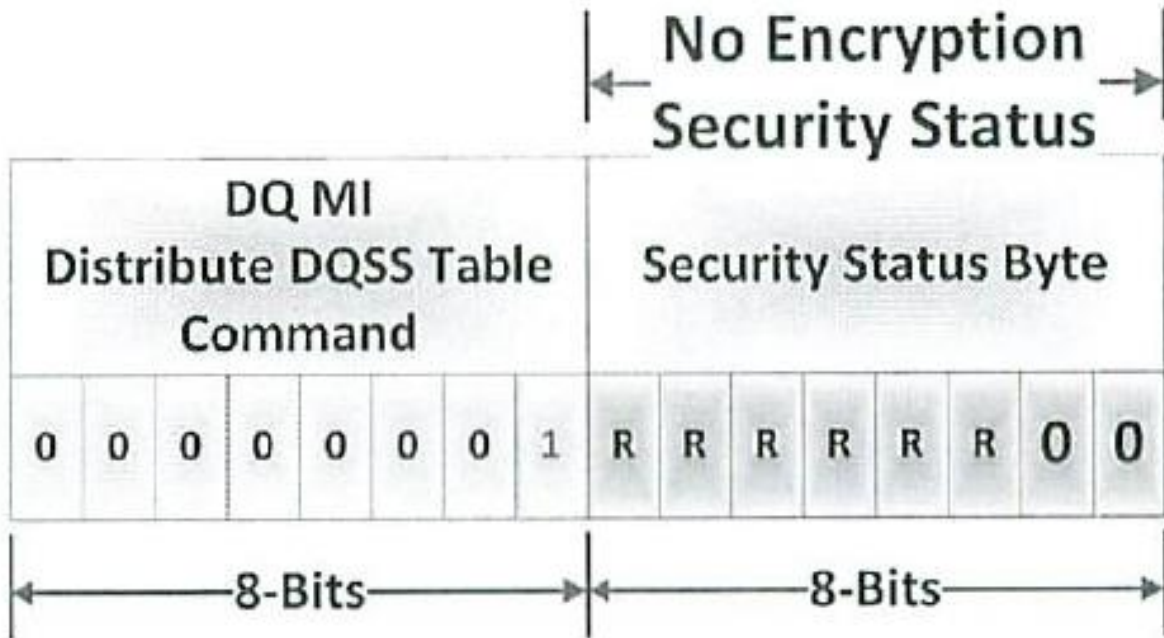

Figure 26

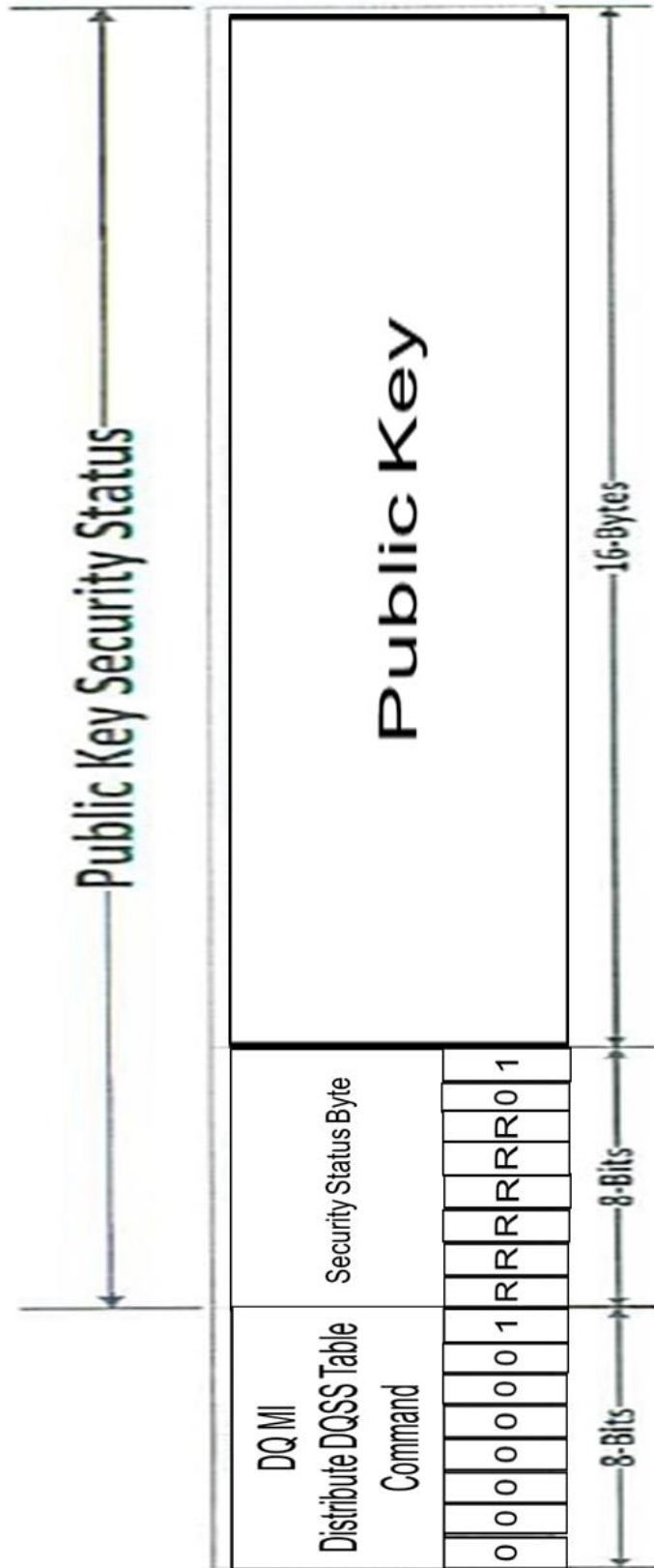

Figure 27

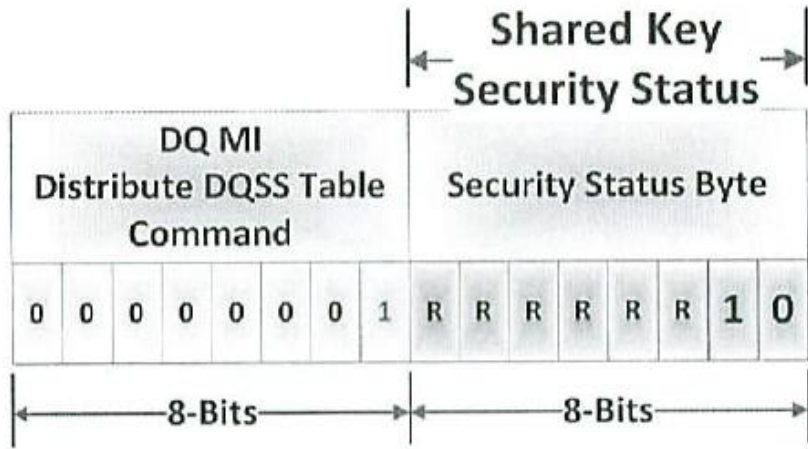

Figure 28

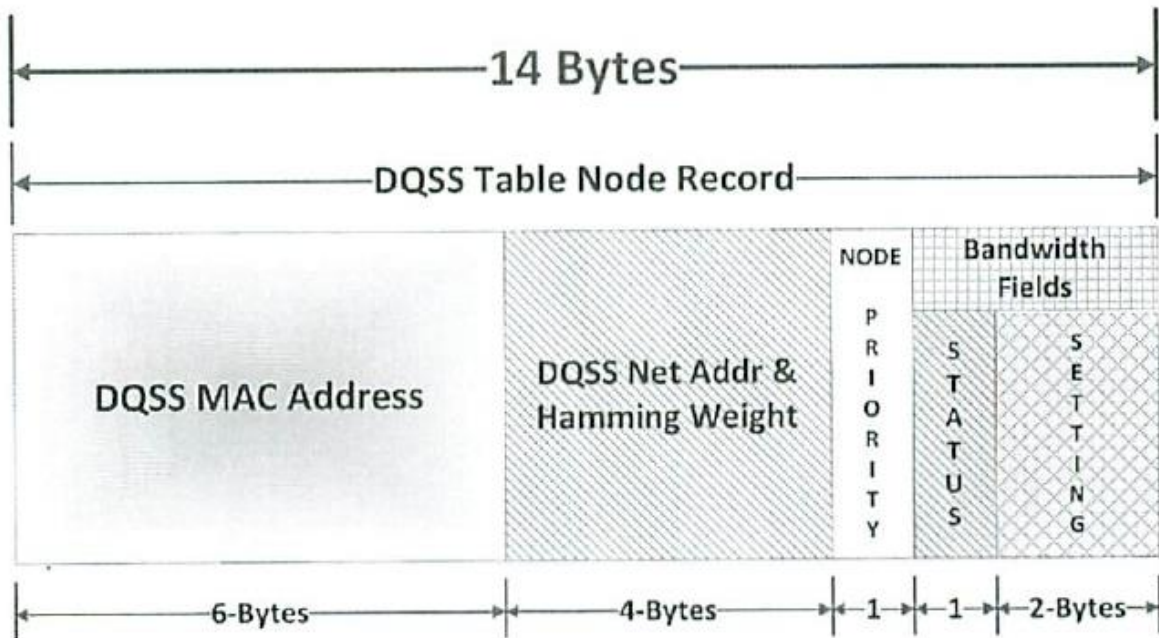

Figure 29

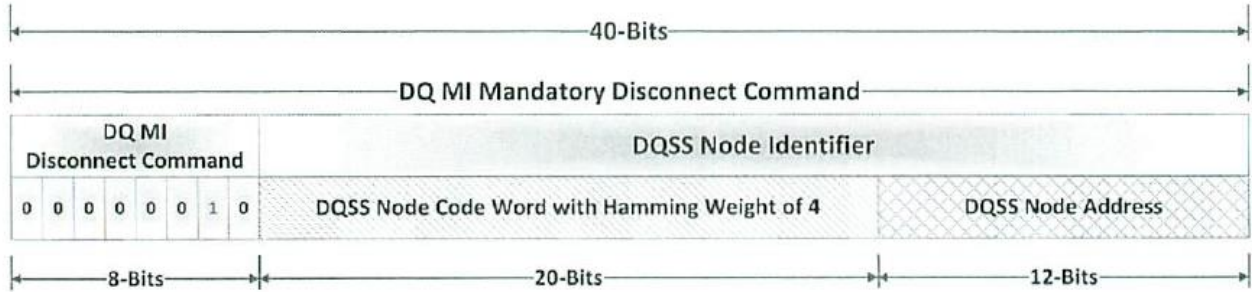

Figure 30

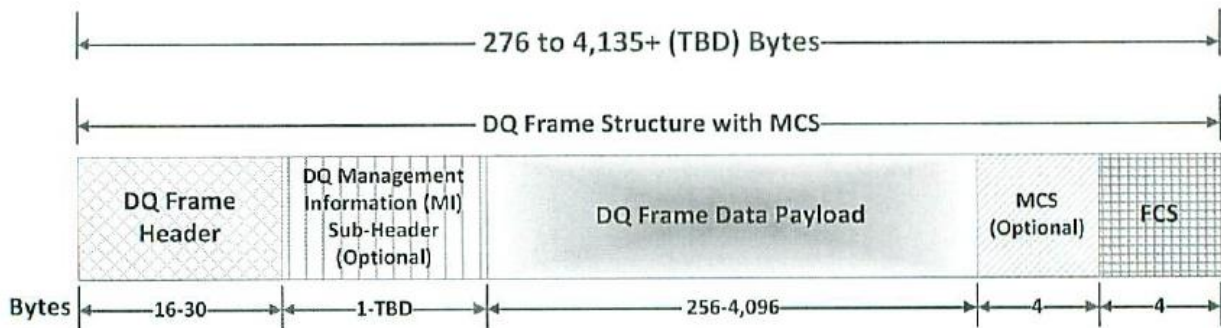

Figure 31

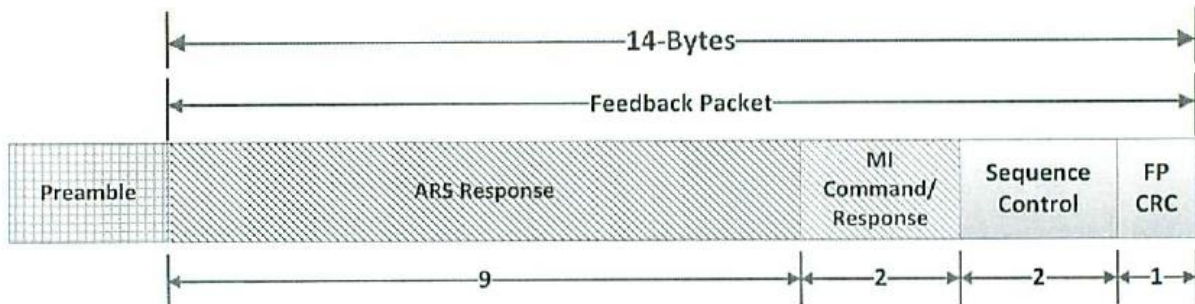

Figure 32

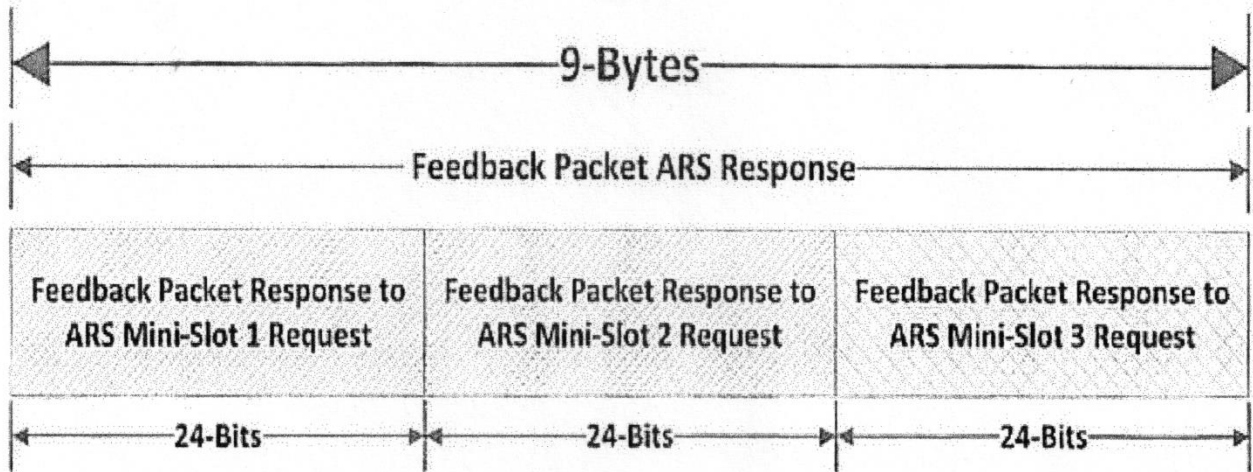

Figure 33

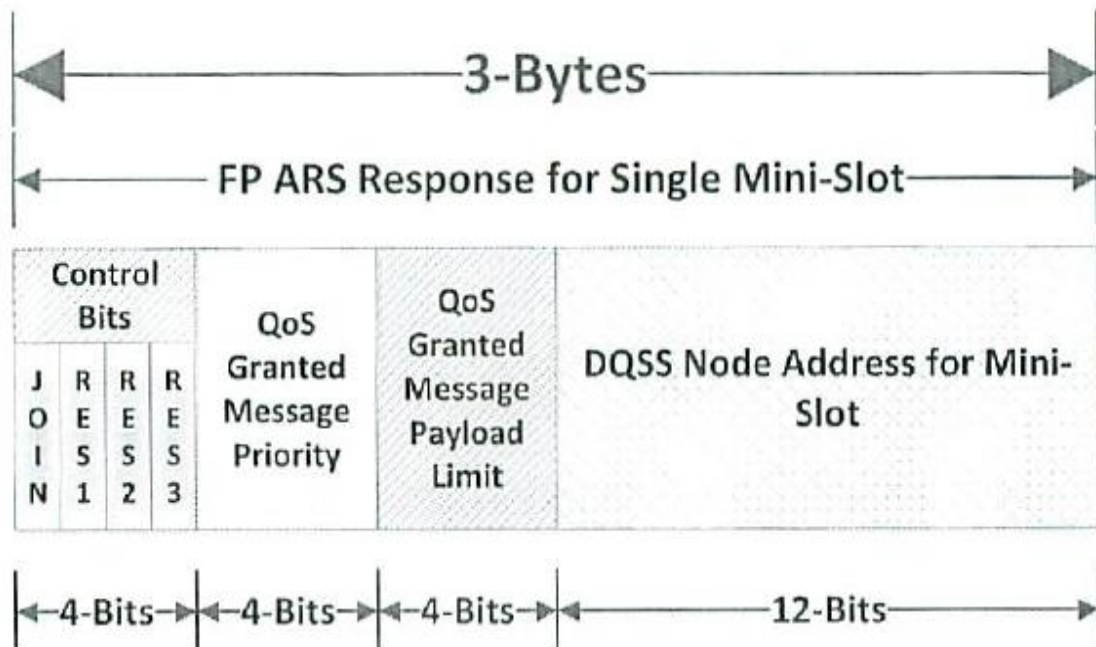

Figure 34

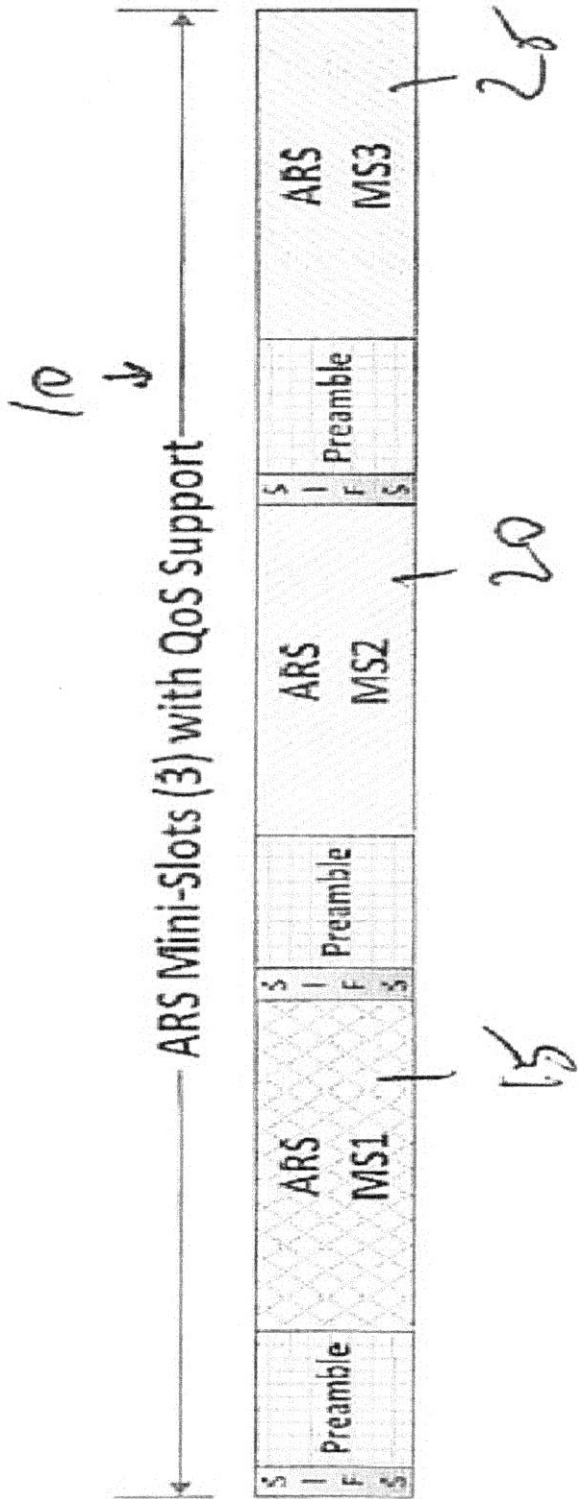

Figure 35

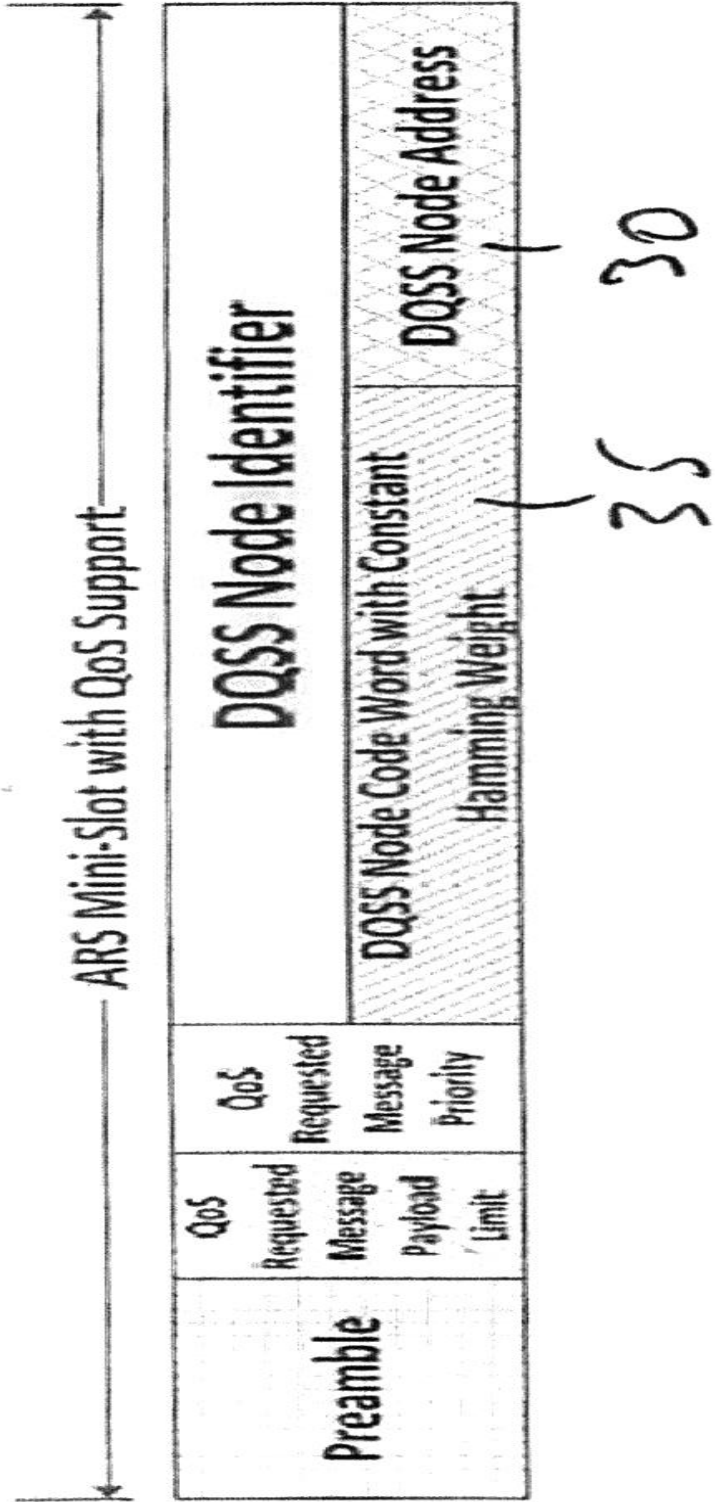

Figure 36

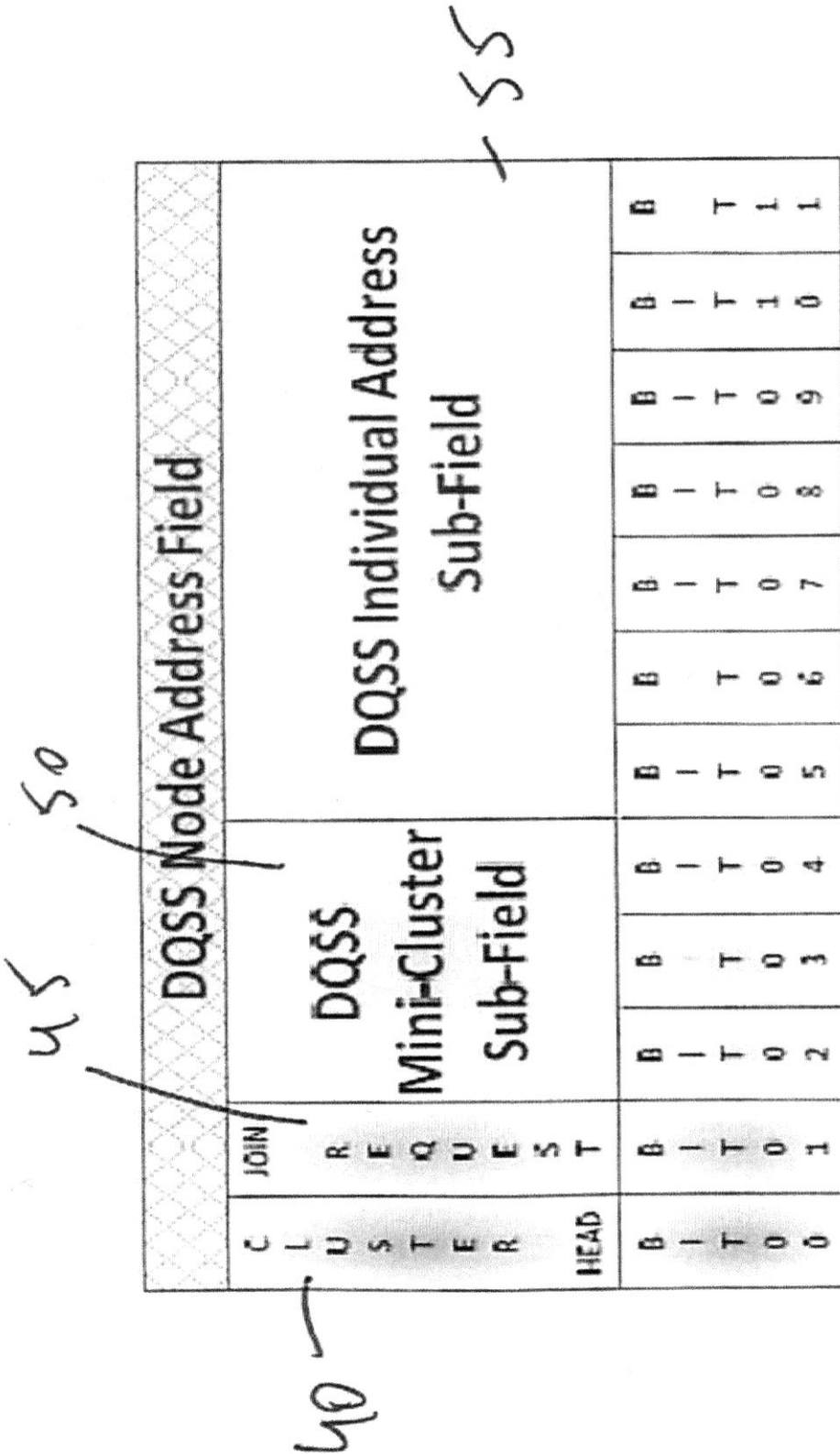

Figure 37

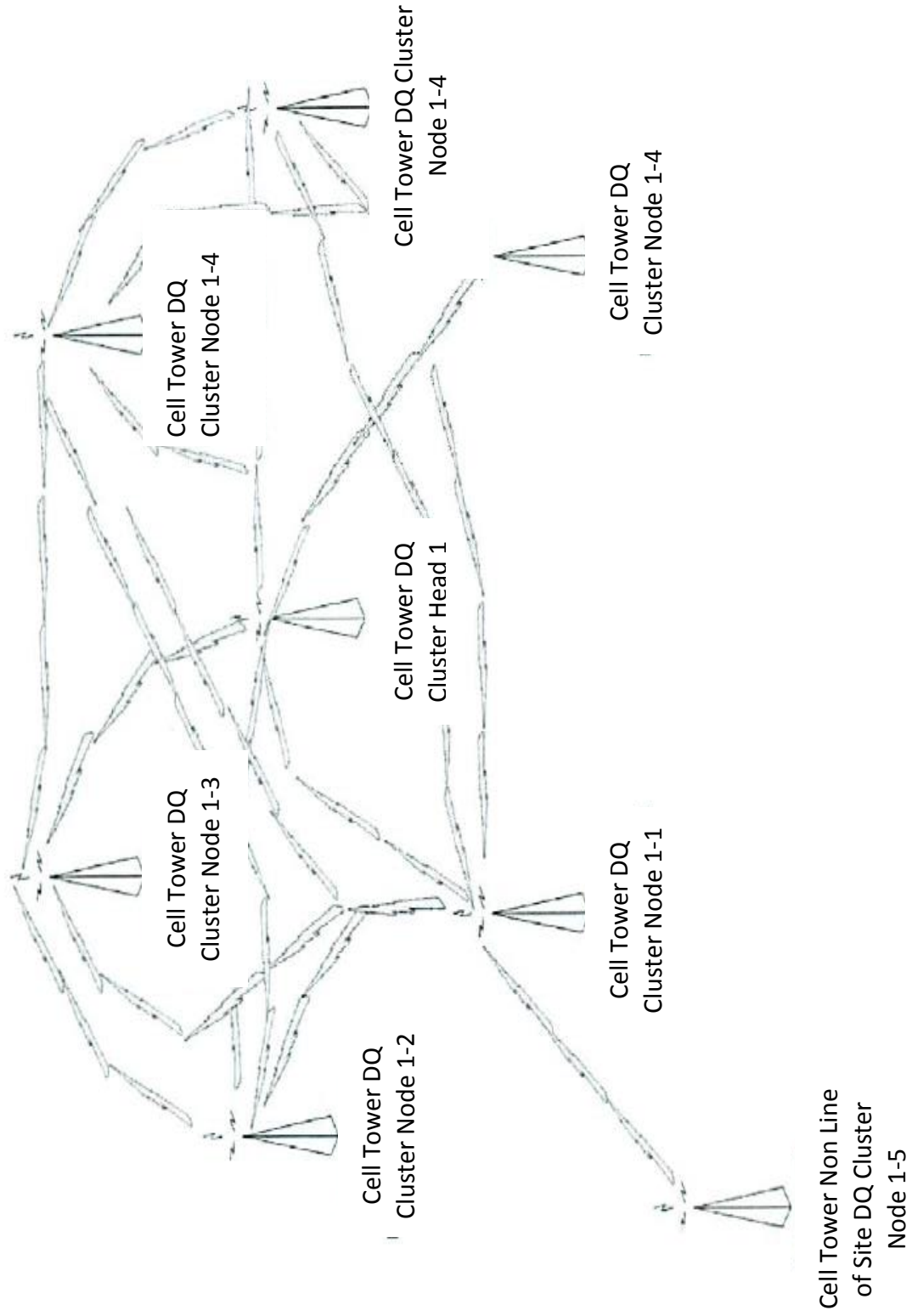

Figure 38

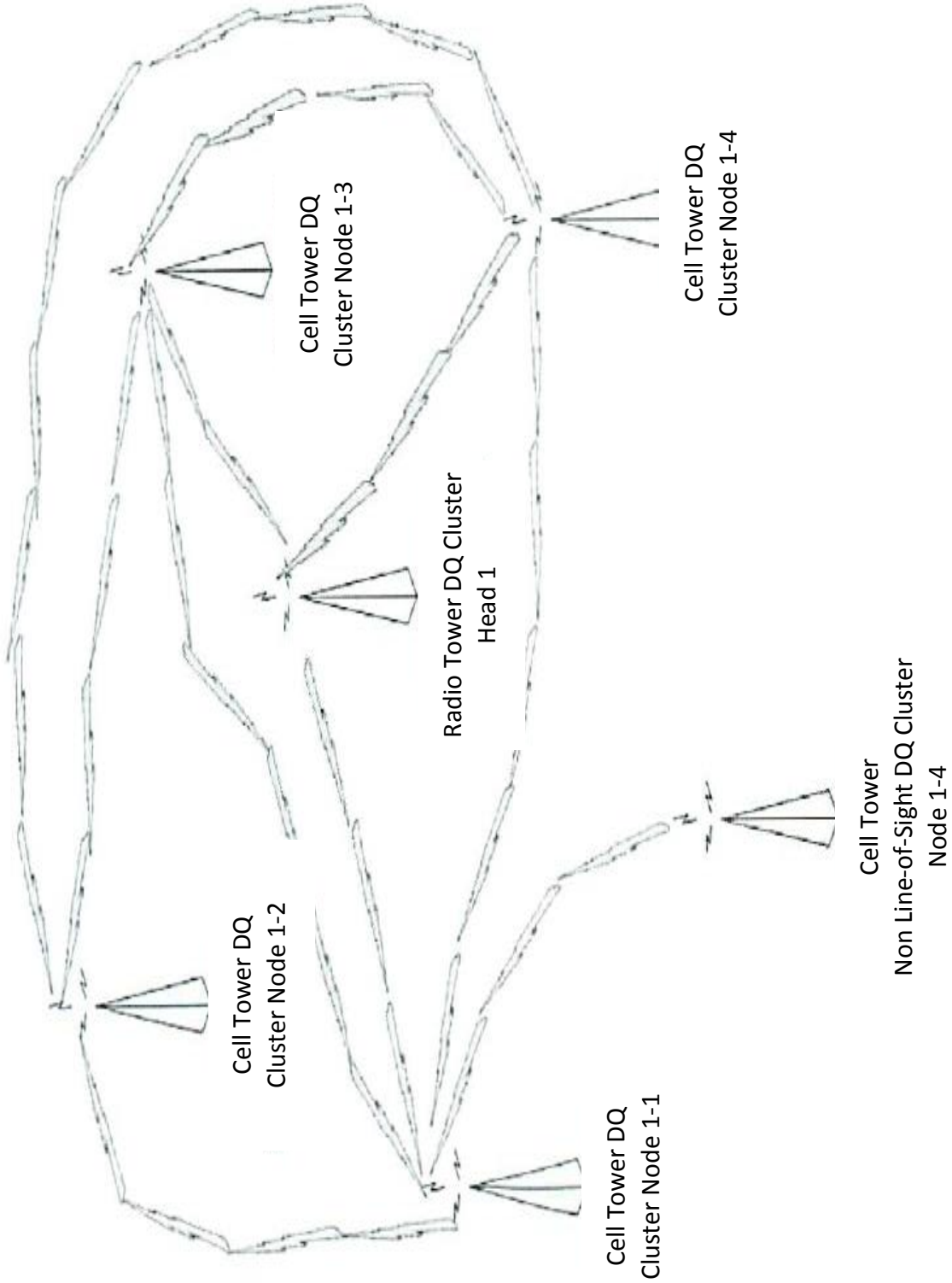

Figure 39

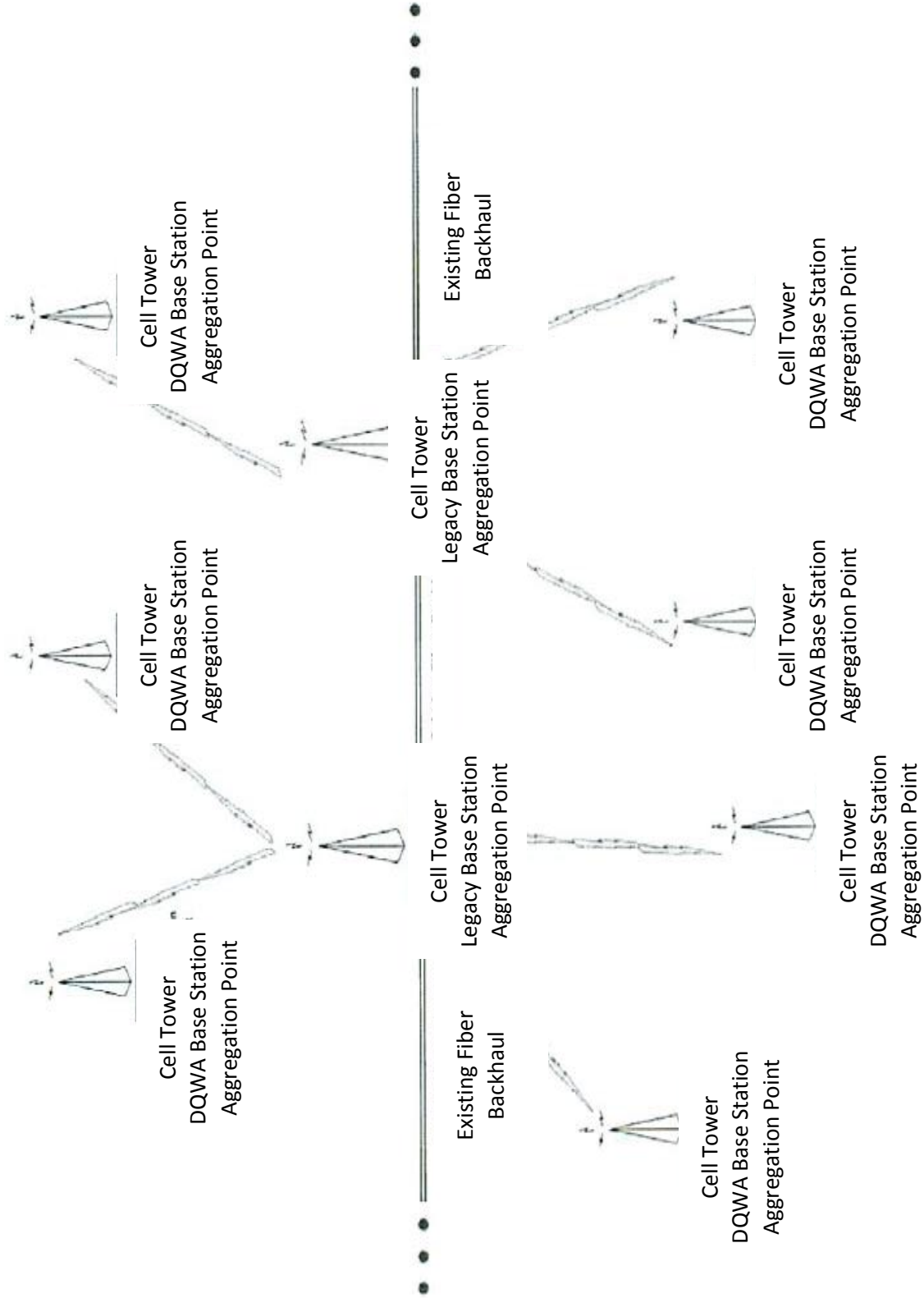

Figure 40

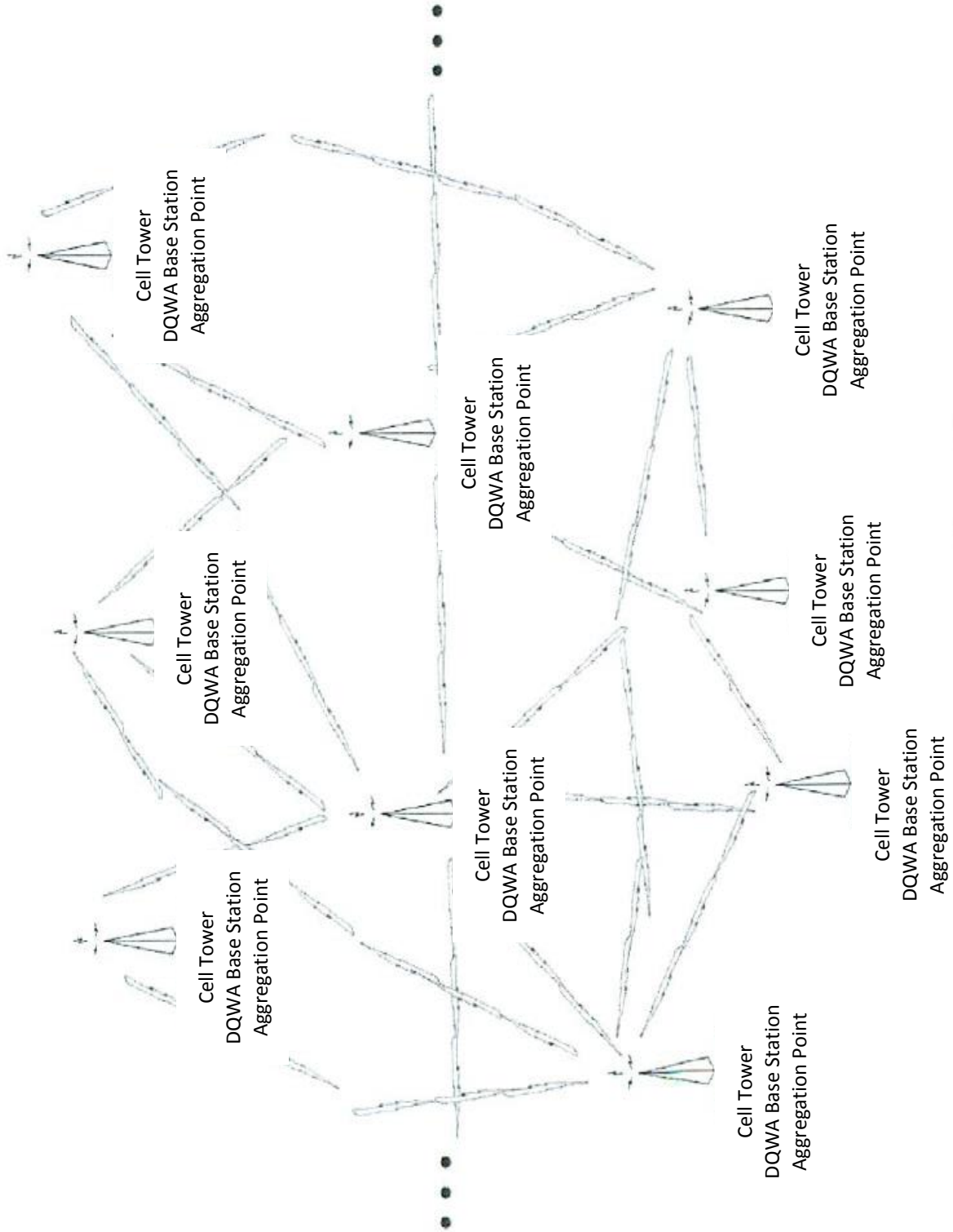

Figure 41

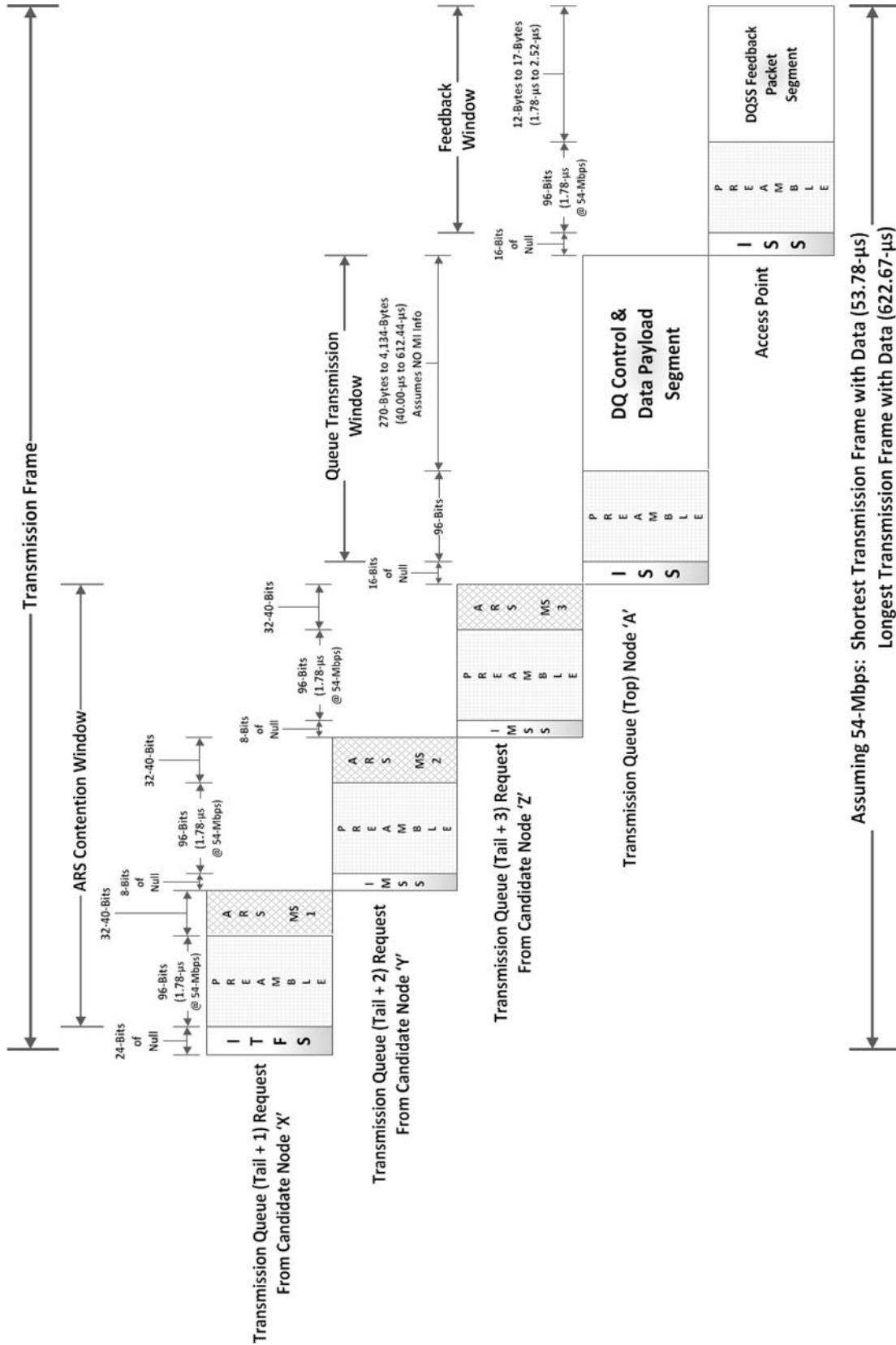

Figure 42

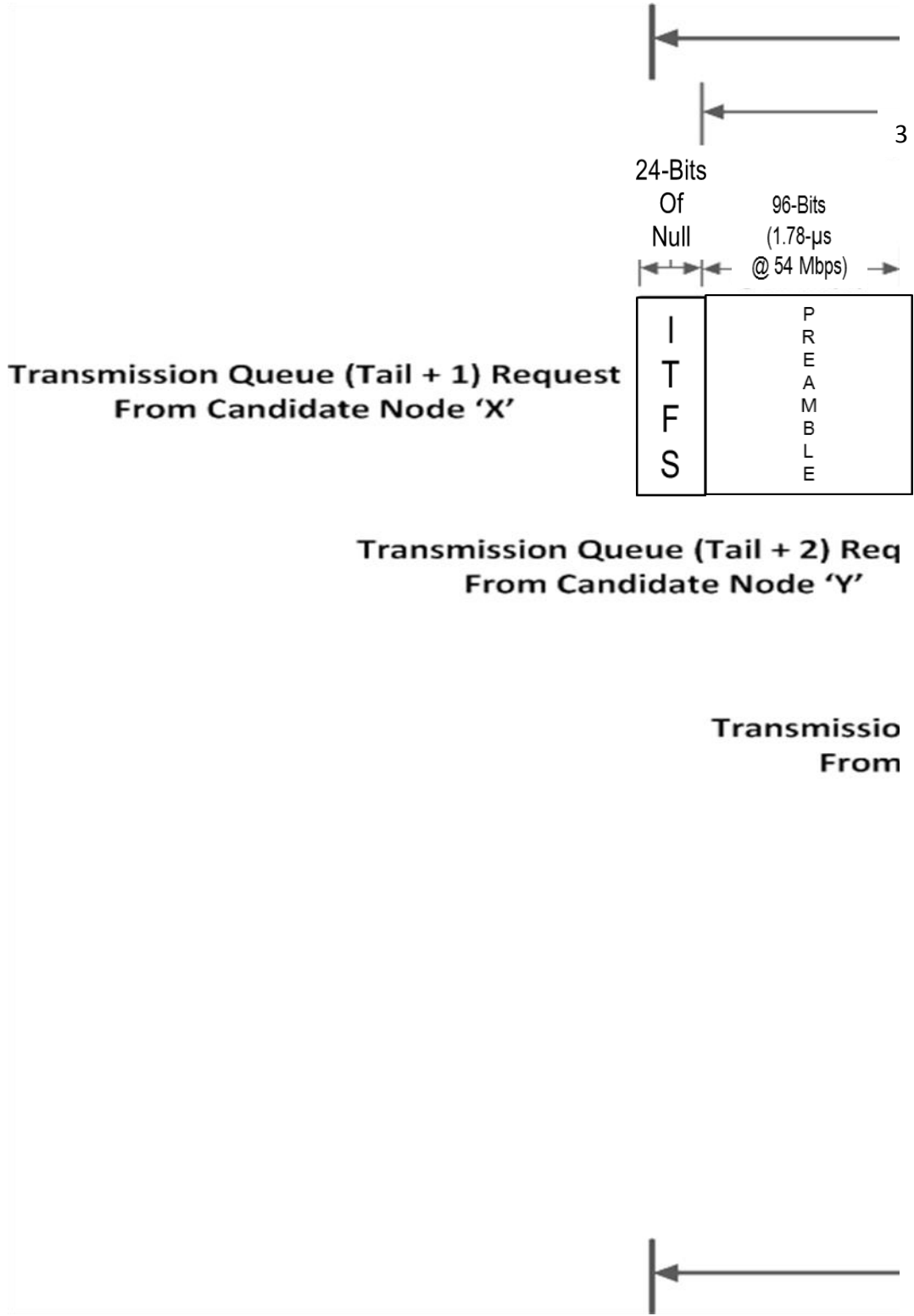
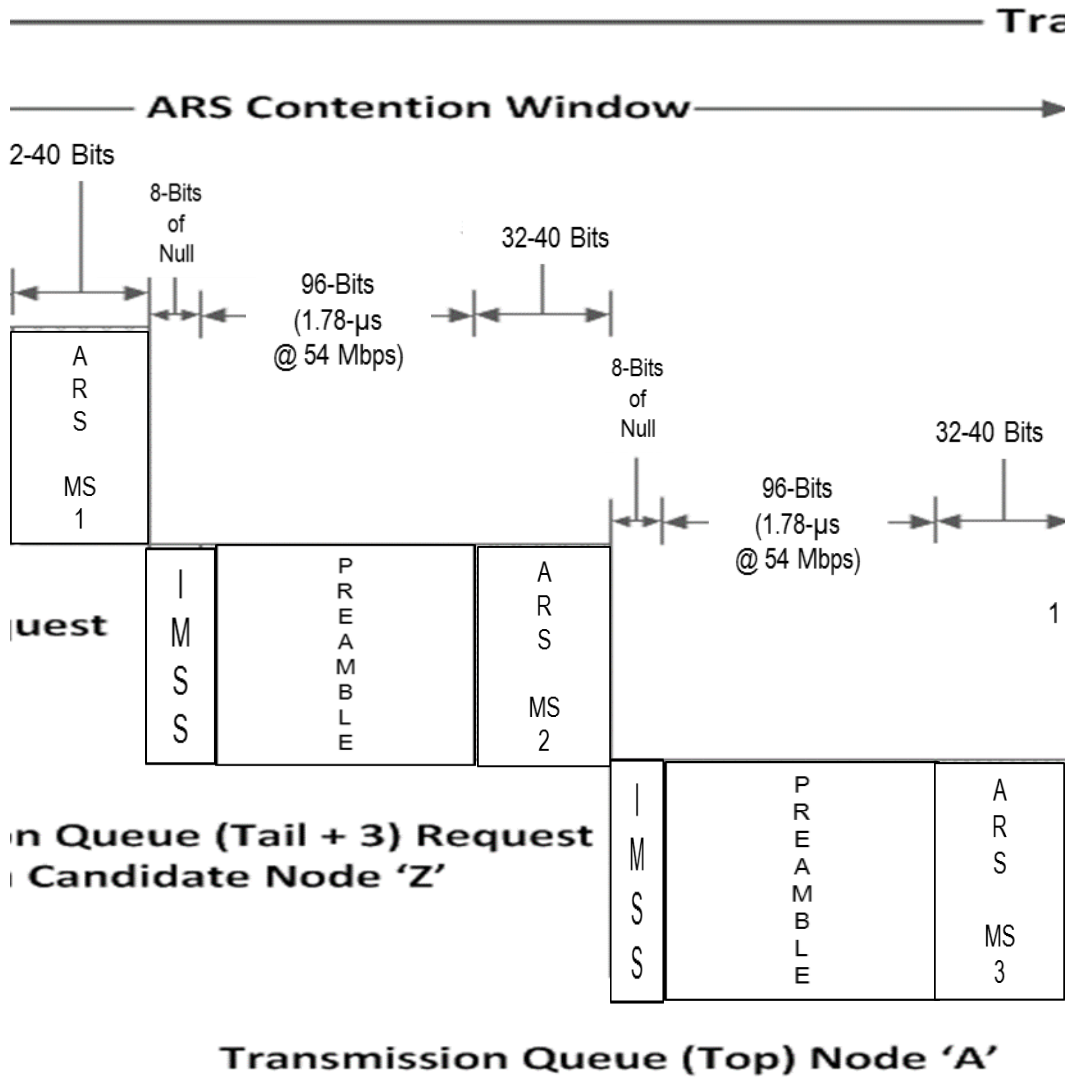

Figure 42a



Assuming 54-Mbps: Shortest
 Longest

Figure 42b

Transmission Frame

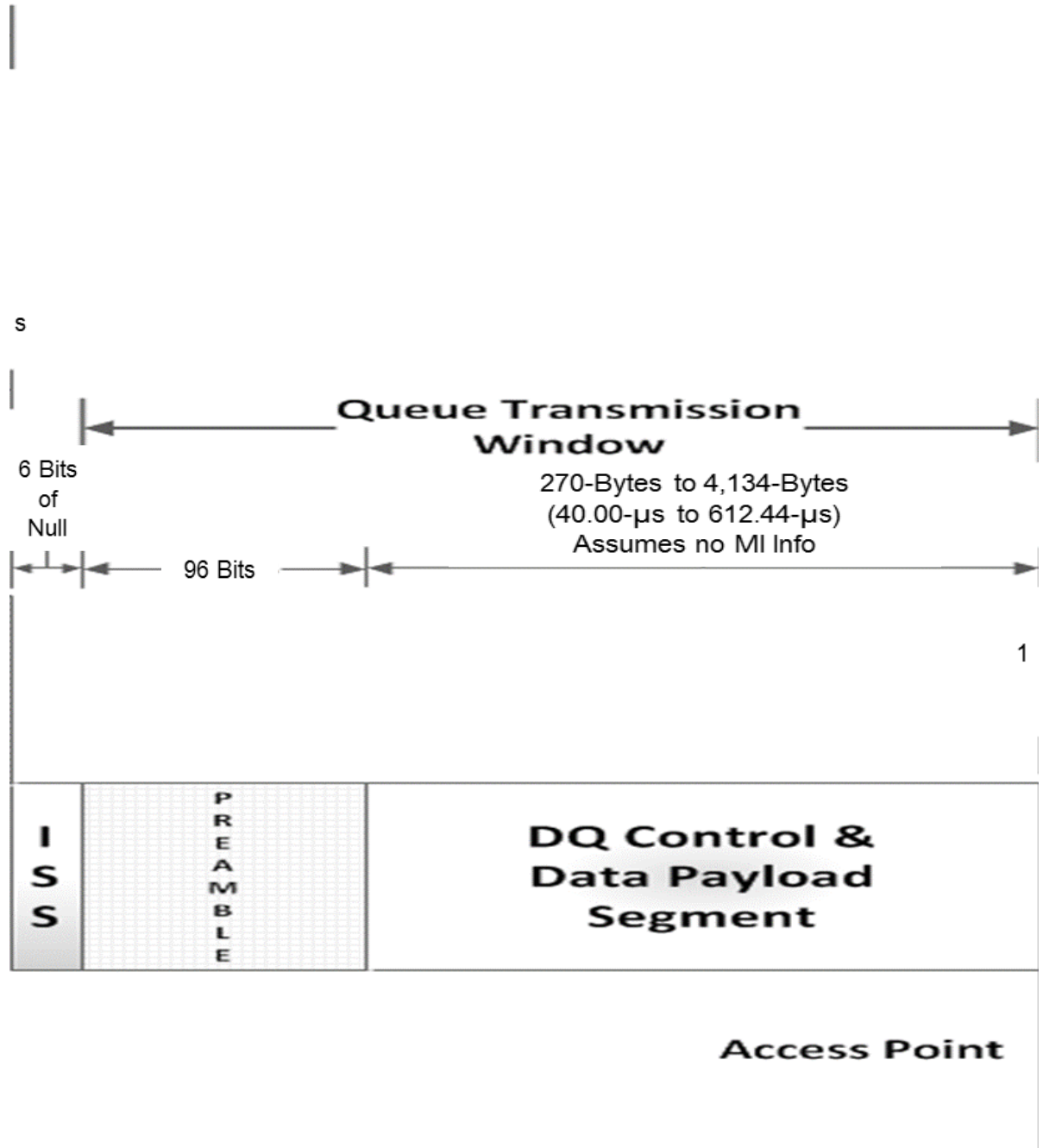

Transmission Frame with Data (53.78-
 Transmission Frame with Data (622.67-

Figure 42c

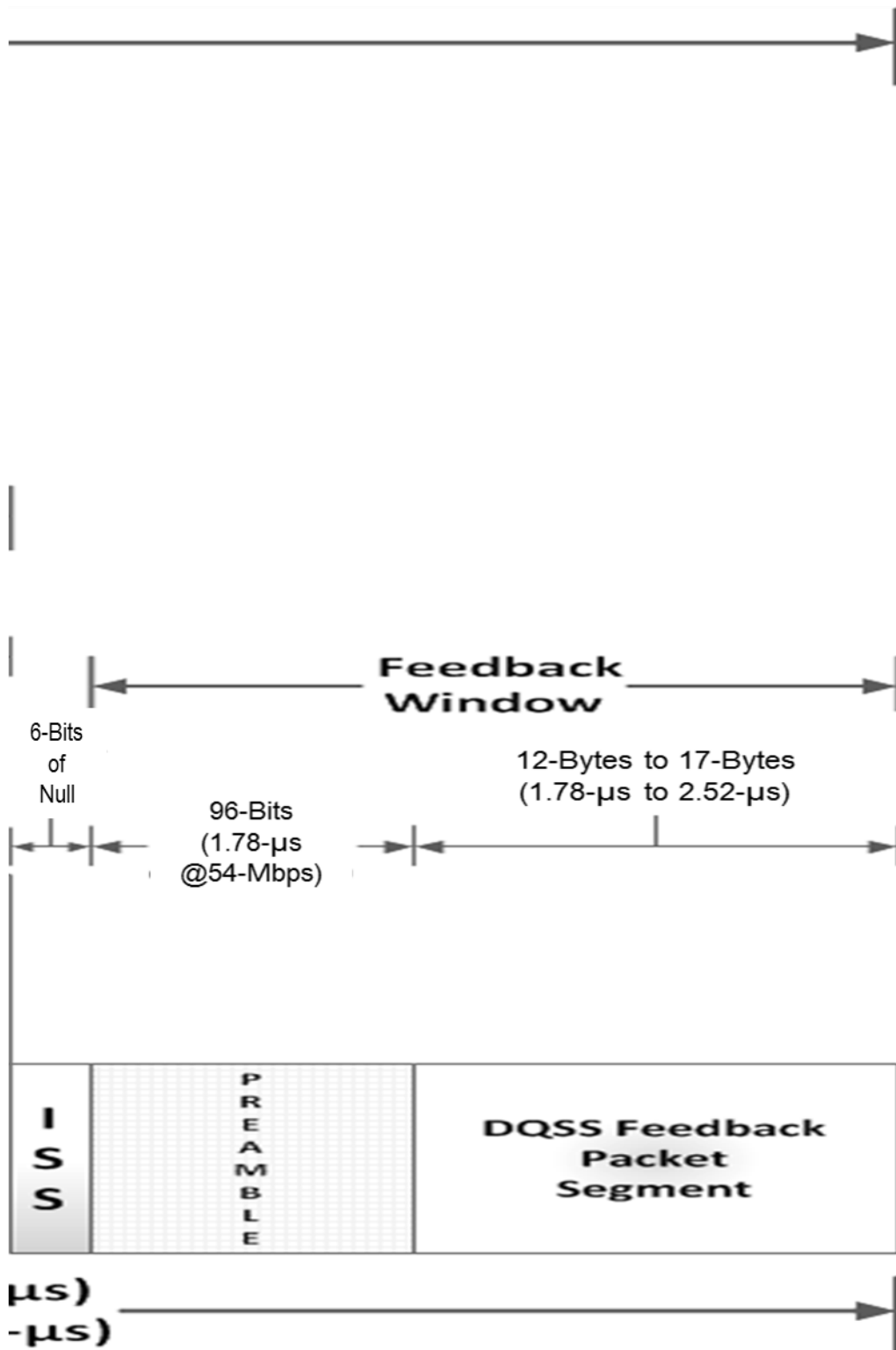

Figure 42d